

2010 PRODUCTION



more than a hook !



M **CERLIANI**
ITALY - Shuttles - Hooks & Bobbin Cases

From the library of: Superior Sewing Machine & Supply, Inc. **January 2010**



Since its foundation **CM Cerliani** has always made Customer Service a business philosophy, numerous specific requests of sewing machines manufacturers and end-users around the world have been developed over the years by our Technical Department.

The hook noisiness has always been a very important factor in the evaluation of a high quality hook, but becomes a real necessity in some specific fields of application.

The specific demand of some of the largest manufacturers of quilting machines in the world, gave way for study of what is today the most recent **CM Cerliani** Patent:

THE NOISELESS HOOK!

The specific implementation of the hook, thanks to special magnets, significantly reduces the vibrations of the basket, the main cause of noise.

Noiseless Hook...



Noiseless Hooks...for quieter sewing!

Ask for this feature as "L" version hook

Italian Pat.: MI2008A002105 / European Pat.: 09276587.5 /
USA Pat. Pend.: 12/625.616 / China App. 200910226595.1 / etc.











Index

Index and Product line description		Pag. 3
Item list (Reader's guidance)		Pag. 4
Technical Sheet	Noiseless Hook system patent	Pag. 2
	Cerliani special coatings	Pag. 24/25
	Adjustable needle guard patent	Pag. 47
Item list	Sinthetic list of CM Hooks, Shuttles and Bobbin Case/Cap with some of the most popular sewing machine references	Pag. 5
Cross Reference List by Original Number	Full list of original numbers	Pag. 32

CERLIANI introduces Hooks, Bobbin cases and Shuttles exclusively of our own production. For their fabrication we guarantee the use of quality choice materials and the constant precision in each phase of manufacturing, so as to insure that each piece will function perfectly as to the smooth sliding, quietness and long durability.

Our technical expertise if requested, can be used for the design and machining of special parts for specific technical requirements. For these reasons our special attention to quality becomes guarantee of the effective economy of the products.

Product line description

	CB Shuttle	Horizontal Rotary Hook	Vertical Rotary Hook
KH Hook to use with bobbin case/cap			
	+	+	+
KP Bobbin case/Cap			
	=	=	=
KK Hook to use with bobbin case/cap complete with bobbin case/cap			
KL Complete capless hook (hook with drop-in bobbin case)			



Item list (Reader's guidance)

Type of CM Article (see previous page)

- KK** = Hook to use with bobbin case/cap complete with bobbin case/cap
- KH** = Hook to use with bobbin case/cap
- KL** = Complete capless hook (hook with drop-in bobbin case)
- KP** = Bobbin case/Cap

Type of gib (only for the rotary hooks):

- Short gib (A TYPE):** for sewing heavy materials.
- Full gib (B TYPE):** for general sewing from light to heavy materials.
- Shorten full gib (B TYPE):** It is a little bit shorter than the full gib.
- Tacking gib (C TYPE):** for sewing medium and light materials.
- Jam proof gib (D TYPE):** this gib is fitted to our jam proof range of hooks (our exclusive patent for a long time). It is connected to the hook body by three screws and three coil springs. If the sewing thread gets caught in the raceway the special mechanism allows the thread to get out without having to remove or dismantle the hook.

Diameter of hole/shaft of the CM Article (HOOK only), measured in mm

Type of bobbin braking system (Bobbin Case/Cap only) is:

- MF** = Bobbin Case with adjustable no backlash spring.
- NBL** = Bobbin Case with no-backlash spring.
- Magnet** = Bobbin Case with magnet to brake the bobbin.
- - = Bobbin Case without any NBL/braking system of the bobbin.

Relation between hook point and needle passing window:

- FA** = The hook point is at the same level as the bottom of the needle passing window. FA is suited for needles with thickness 70 through 100 (metric, corresponding to American Singer sizes 10 through 16) and is used for all generic stitching on normal fabrics.
- FB** = The hook point is higher than the bottom of the needle passing window. FB is suited for needles with a very deep groove, such as Singer MR, Schmetz SERV 7 or Groz-Beckert SAN as well also for needles with thickness 120 through 160 (metric, corresponding to American Singer sizes 19 through 23).

XX	Xxxxx Xxx	XXXX	xxxx	XX
0000000000 XXXXXXXXXXXX xxxxx; xxxxx; xxxxx 0000000000 XXXXXXXXXXXX xxxxx; xxxxx; xxxxx 0000000000 XXXXXXXXXXXX xxxxx; xxxxx; xxxxx				
000.00.000				
Code Similar Article		XXXXXXXXXXXXXXXXXX		
000.00.000		XXXXXXXXXXXXXXXXXX		

Some of the most popular:

- original number
- sewing machine manufacturer
- machine model (;)

For more correspondences, please visit our website: www.cerliani.it

Indicates the most important explanatory notes of the CM ARTICLE



Indicates in what the similar article is different to the present article.

Indicates one of the other CM similar articles. For more similar articles, please visit our website: www.cerliani.it

CM ARTICLE NUMBER

PICTURE OF THE CM ARTICLE

**NAVETTA OSCILLANTE
RING SHUTTLE
BARRELL-SCHIFFCHEN
NAVETTE OSCILLANTE
LANZADERA OSCILLANTE
BARQUINHA DE MÁQUINA VIBRANTE**





	0005 002904 DÜRKOPP-ADLER 104; 105; 165; 166		11540-4-00 NECCHI 630; 631; 632; 640; 641; 642; 643; 644 98622 SINGER 45K				
112.00.025		112.00.031					





**GANCIO BC
CB SHUTTLE
CB GREIFER
CROCHET BC
GARFIO CB
LANÇADEIRA BC**



	6016 CONSEW 118; 18 2515 SINGER 15-30; 16; 68-39; 69		91-006 560-05 PFAFF 3125 A; 3125 B; 3135 A; 3331; 3334; 3335; 3336 A; 3370 A; 3370 B; 34 A; 34 B		91-006 694-05 PFAFF 3125 C; 3331; 3336 C; 3337 C; 3370 C		26327-0-00 NECCHI 500; 514; 523; 534; BD; LELIA; NORA; SA
115.00.018		115.00.074	Code Similar Article 115.00.257	115.00.076	Code Similar Article 115.00.269	115.00.098	
			HARD CHROMIUM PLATED		HARD CHROMIUM PLATED		
	210 C CONSEW 30 0037 001514 w/o BC DÜRKOPP-ADLER 37 12393 SINGER 31-15; 431F 200A; 44		40028 SINGER 269W		1500-2-04 NECCHI 421; 603; IA		0570 001241A w/o BC DÜRKOPP-ADLER 570
115.00.110		115.00.129	Code Similar Article 115.00.233	115.00.130		115.00.209	Hard chromium plated
			HARD CHROMIUM PLATED				
	40028-003 SINGER 269W		91-006 560-45 PFAFF 3331; 3337 A; 3337 B; 34 A; 34 B		91-006 694-45 PFAFF 3135 C; 3336 C; 34 C		5-0258 GLOBAL BT-1850 GOLDEN WHEEL CS-8150-558 B1818-280-000 JUKI LK-1950
115.00.233	Hard chromium plated	115.00.257	Hard chromium plated	115.00.269	Hard chromium plated	115.00.273	Hard chromium plated
	GOLDEN WHEEL CS-8150; CSA-3450-5 D1818-282-NOO JUKI LK-1850J 07-128A-120H SUNSTAR SPS/A-B1201(H)		152685-301 BROTHER LK3-B4300E; LK3-B4310E; LK3-B438E; LK3-B441 MS01A0120 MITSUBISHI PLK-03BTA; PLK-0804		152687-201 BROTHER LK3-B430E; LK3-B436 MS01A1120 MITSUBISHI PLK-0504; PLK-0604 G182 SIRUBA PK533-M		91-230 414-45 PFAFF 3339 A; 3339 B; 3339 C
115.00.274	Hard chromium plated	115.00.275	Hard chromium plated	115.00.276	Hard chromium plated	115.00.280	Hard chromium plated

KH	 <u>418045</u> SINGER 469U; 469U 108H; 469U 139H; 569U; 569U 108-H; 569U 139 H; 569U 141-M; 569U 142-H				
115.00.285	Hard chromium plated				

**GANCIO BC GRANDE CAPACITA'
LARGE CAPACITY CB SHUTTLE
GROSSRAUM CB GREIFER
CROCHET BC GRANDE CAPACITE
GARFIO CB DE GRAN CAPACIDAD
LANÇADEIRA OSCILANTE DE GRANDE CAPACIDADE**

KH	 <u>MS17A1120</u> MITSUBISHI PLK-A3530 <u>281776</u> SINGER 469U	KH	 <u>MA10A0120</u> MITSUBISHI PLK-E1010; PLK-E6030 <u>282522</u> SINGER 469U <u>G181</u> SIRUBA PK533 L; PK588	KH	 <u>B1818-210-000</u> JUKI AMS-211CGS; AMS-220CGS; AMS-222BC; AMS-222CG; AMS-224CG	KH	 <u>B1818-210-DOA</u> JUKI AMS-210D; LK-1910; LK-1920; LK-1930
115.10.000	Heavy material; Hard chromium plated LIGHT MATERIAL	115.10.001	Light material; Hard chromium plated HEAVY MATERIAL	115.10.002	Hard chromium plated	115.10.006	Light material; Hard chromium plated HEAVY MATERIAL
Code Similar Article 115.10.001		Code Similar Article 115.10.000				Code Similar Article 115.10.007	

KH	 <u>B1818-210-DOB</u> JUKI AMS-210D; LK-1910; LK-1920; LK-1930	KH	 <u>B1818-205-000</u> JUKI AMS-205C; AMS-215C; AMS-224CS	KH	 <u>B1818-205-00B</u> JUKI AMS-220CHS	KH	 <u>SA2173-101</u> BROTHER BAS-311F-01; BAS-311F-L1; BAS-326F-01; BAS-341F-01; BAS-342F-01; BAS-7050
115.10.007	Heavy material; Hard chromium plated LIGHT MATERIAL	115.10.008	Light material; Hard chromium plated HEAVY MATERIAL	115.10.009	Heavy material; Hard chromium plated LIGHT MATERIAL	115.10.010	Hard chromium plated
Code Similar Article 115.10.006		Code Similar Article 115.10.009		Code Similar Article 115.10.008			

KH	 <u>SA1890-101</u> BROTHER BAS-311F-02; BAS-311F-03; BAS-326F-02; BAS-7050	KH	 <u>07-S032S-306H</u> GARUDAN GPS series SUNSTAR SPS/A-1306(HS)		
115.10.011	Hard chromium plated	115.10.013	Heavy material; Hard chromium plated		

**GANCIO AD OCCHIALE
ROTARY HOOK GATE TYPE
BRILLENGREIFER
CROCHET A LUNETTE
GARFIO DE LUNETA
LANÇADEIRA ROTATIVA TIPO LUNETA**









KH	 <u>H76-29</u> ANKER-PHOENIX 280-388 <u>574.051</u> ZSK 166; 166E; 7000; 8000				
120.00.027					



GANCIO ROTATIVO
ROTARY HOOK
UMLAUFGREIFER
CROCHET ROTATIF
GARFIO ROTATIVO
LANÇADEIRA ROTATIVA





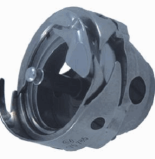



















KH	Full Gib	7,24 H	FA	KH	Full Gib	5,53 H	FA	KH	Full Gib	7,24 H	FA	KH	Full Gib	7,24 H	FA
	<u>2110424-310</u> 90 12 00 <u>127119FG</u>	CONSEW 100; 101; 105 REFREY 906; 910; 918 SINGER 95-40; 96-40			<u>142020FG</u>	SINGER 103K; 95-10; 96-10			<u>0096 152814 w/o BC</u> DÜRKOPP-ADLER 96 SINGER 319; 320				<u>1 12 329</u> <u>554575-4-00</u>	ALFA 127; 157 NECCHI 860	
130.01.000				130.01.018				130.01.025				130.01.031			
KH	Full Gib	7,24 H	FA	KH	Full Gib	5,53 H	FA	KH	Full Gib	5,53 H	FA	KH	Full Gib	7,24 H	FA
	<u>0199 152814 w/o BC</u> DÜRKOPP-ADLER 289; 489					ANKER-PHOENIX 29; 39			<u>173239</u> SINGER 306M; 319; 320				<u>173239</u> SINGER 306M; 319; 320		
130.01.039				130.01.046				130.01.049				130.01.052			
KH	Full Gib	7,24 H	FA	KH	Full Gib	7,24 H	FA	KH	Full Gib	7,24 H	FA	KH	Full Gib	7,24 H	FA
	<u>110525-4-00</u> NECCHI RZI				<u>52310-4-00</u> NECCHI 800; 810; RVG; RVM				OMAC EOS				<u>971842-4-00</u> NECCHI 527; 529; 533; 535; 720; 721; 840 <u>0009010050</u> RESTA H228		
130.01.054				130.01.097				130.01.109				130.01.111			
KH	Short Gib	7,24 H	FB	KH	Short Gib	7,24 H	FB	KH	Short Gib	5,53 H	FB	KH	Full Gib	7,24 H	FB
	<u>541968</u> GEMSY 391 SINGER 20U-13; 20U-23 ZOJE ZJ20U93				<u>111272-901</u> BROTHER DB2-B767; DB2-B767-5 <u>127119</u> SINGER 95-40; 96-40 <u>103109010</u> YAKUMO (NAKAJIMA) DBU-180-2; DSN-80-3				<u>142020</u> SINGER 103K; 95-10; 96-10				<u>541674</u> GOLDEN WHEEL CS-2180 PROTEX (TONGYU) GG-20U SINGER 20U-23; 20U-31; 20U-34		
130.01.113				130.01.124				130.01.126				130.01.129			
KH	Short Gib	7,24	FB	KH	Short Gib	7,24 H	FB	KH	Short Gib	7,94 H	FB	KH	Short Gib	7,24 H	FB
	<u>8-6-1100</u> MARCO Model				<u>117677-901</u> BROTHER LE2-B861-1 <u>B70</u> CONSEW 199 R <u>B1830-027-OAO</u> JUKI LZ-27; LZ-29; LZ-40				<u>174045</u> SINGER 195K; 196K				<u>112041-901</u> BROTHER BAS-400; LE2-B861-7 <u>JL6100-0A</u> GOLDEN WHEEL CS-335BH; CS-335U WOEI RONG (SW/JK) WR-652		
130.01.131				130.01.135				130.01.139				130.01.147			
KH	Short Gib	7,24 H	FB	KH	Short Gib	7,94 H	FA	KH	Short Gib	7,94 H	FA	KH	Short Gib	7,94 H	FA
	<u>279</u> CONSEW 199 R MEISTERGRAMM M700; M800				<u>KF220310</u> BARUDAN 3EAM serie; BEDSH serie; BEMR serie; BEMS serie; BENS serie; BENT serie; BESR serie				RICHPEACE RP-CEM (ALL CLASSES) SUNSTAR SWF/A-UK 1204-45 <u>ME0505000AMQ</u> TAJIMA TMBE; TMFD-C; TMLG				<u>ESMPZ00050</u> HAPPY HCM; HM4; HMF; HMS		
130.01.148	Long point			130.01.357	Code Similar Article 130.01.357TS	TS COATED		130.01.399	Code Similar Article 130.01.399TS	TS COATED		130.01.403	Code Similar Article 130.01.403TS	TS COATED	





























 KH Short Gib 7.94 H FA KF220710 BARUDAN BEMS serie; BENS serie MELCO EMC 10/12; EMT 10/12T 050210140016 TAJIMA TFGN; TMBE; TMFN 130.01.408 Under trimming mach. Code Similar Article 130.01.408TS TS COATED	 KH Short Gib 7.94 H FA KF221000 BARUDAN BEDSH serie; BEDIH serie; BEDIYHE serie ME0505E20AMQ TAJIMA Model 130.01.415 Elliptical; Under trimming mach. Code Similar Article 130.01.415TS TS COATED	 KH Short Gib 7.94 H FA 32644 DC20 MELCO AMAYA 130.01.430DC20 DC20 COATED	 KH Jam Proof Gib 7.24 H FA 127119JP SINGER 95-40; 96-40 130.02.000
 KH Jam Proof Gib 5.53 H FA 52089JP SINGER 103K; 95-10; 96-10 130.02.018	 KH Jam Proof Gib 5.53 H FA ANKER-PHOENIX 29; 39 130.02.030	 KH Jam Proof Gib 7.24 H FA KACHIRAN NEW LIFE 91-106 253-91 w/o BC PFAFF 1010; 1025; 1037; 1047; 1050; 1069; 1150; 1151 130.02.500	 KH Full Gib 7.24 H FA 91-009 191-91 w/o BC PFAFF 134; 134-0-6 130.03.000
 KH Full Gib 7.24 H FA 91-063 090-91 w/o BC PFAFF 234 130.03.008	 KH Full Gib 7.24 H FA 91-009 264-91 w/o BC PFAFF 133; 134-0-31; 134-0-K-6 130.03.013	 KH Full Gib 7.24 H FA 91-009 268-91 w/o BC PFAFF 134-0-92; 138 130.03.014 With hook fastening screw Code Similar Article 130.03.017 WITH HOOK FASTENING GRUB SCREW	 KH Full Gib 7.24 H FA 26010003 IVOMAQ CI 2100 2AV 91-105 490-91 w/o BC PFAFF 138; 230; 260; 331 WANPING TW3-P335 130.03.017 With hook fastening grub screw Code Similar Article 130.03.014 WITH HOOK FASTENING SCREW
 KH Full Gib 7.24 H FA 91-064 661-91 w/o BC PFAFF 238 130.03.038	 KH Full Gib 7.24 H FA 0069 005814 w/o BC DÜRKOPP-ADLER 69 GOLDEN WHEEL CS-2280 19985 SEIKO HC-2B; LSC-8BV 130.03.040	 KH Full Gib 7.24 H FA 573.020 ZSK 166M; 167; 168; 170-174; Serie J; Serie L; Serie M; Serie T; Serie X; Serie XB; Serie XL 130.03.043 Code Similar Article 130.03.043DC20 DC20 COATED	 KH Full Gib 7.24 H FB 91-163 260-91 w/o BC PFAFF 134-0-92; 138; 230; 260; 331 130.03.048 Needle slot 13.5mm
 KH Full Gib 7.24 H FA 060581 w/o BC GLOBAL WF-1335-B 91-060 581-91 w/o BC PFAFF 335-G (-900/..) WANPING TW3-P335B 130.03.057 Code Similar Article 130.00.335 COMPLETE KK HOOK WITH BC	 KH Shorten full 7.24 H FA 573.019 ZSK 166M; 167E; 168E; 169E; 170E; 171E; 172; 174; Serie J; Serie L; Serie M; Serie T; Serie X; Serie XB; Serie XL 130.03.059 Code Similar Article 130.03.059DC20 DC20 COATED		
 KH Full Gib 7.24 H FA 91-171 820-91 w/o BC PFAFF 461-469; 480-489; 560; 561 130.04.000 With metric screw	 KH Full Gib 7.24 H FA 91-265 280-91 w/o BC PFAFF 467; 469; 481 (-900/..); 481-900/..; 483-926/01; 561 (-900/..) 130.04.007 Under trimming mach.	 KH Full Gib 7.24 H FB 91-265 225-91 w/o BC PFAFF 2438; 2438-916; 437; 437-900/..; 438; 838; 838-900/..; 939 130.04.012	 KH Full Gib 7.24 H FA 91-265 262-91 w/o BC PFAFF 3519-12; 3519-3; 3822-1/02 (G); 3822-1/22 (G); 480 G; 489-G (-900/..); 489-G-900/..; 489-G-926/01; 563-G (-900/..); 563-G-900/.. 130.04.075 Code Similar Article 130.00.336 COMPLETE KK HOOK WITH BC

GANCIO ROTATIVO ALTA VELOCITÀ
HIGH SPEED ROTARY HOOK
HOCHGESCHWINDIGKEITS - UMLAUFGREIFER
CROCHET ROTATIF GRANDE VITESSE
GARFIO ROTATIVO DE ALTA VELOCIDAD
LANÇADEIRA ROTATIVA DE ALTA VELOCIDADE



	KH Full Gib 7.24 H FA	91-265 265-91 w/o BC PFAFF 460		KH Full Gib 7.24 H FA	95-774 726-91 w/o BC PFAFF 3588; 3588-02/01		KH Full Gib 7.94 H FA	143342 SINGER 241; 251		KH Full Gib 7.94 H FA	143342SN SINGER 241; 251
130.04.094			130.04.098	Under trimming mach.		130.05.000			130.05.008	For Synthetic thread	
						Code Similar Article 130.05.008	FOR SYNTHETIC THREAD				
	KH Full Gib 7.94 H FA	2121604-310B CONSEW 315 R B1830-415-OAO JUKI DLN-415; DLN-5410N 272138 SINGER 400W; 451K; 600W		KH Full Gib 7.94 H FA	272138 SN SINGER 400W; 402W; 451K; 600W		KH Full Gib 8.10 H FA	61407BFG UNION SPECIAL 61200; 61900; 63900		KH Full Gib 8.10 H FA	61407BFGSN UNION SPECIAL 61200; 61400; 63900
130.05.015			130.05.028	For Synthetic thread		130.05.035			130.05.050	For Synthetic thread	
Code Similar Article 130.05.028	FOR SYNTHETIC THREAD					Code Similar Article 130.05.050	FOR SYNTHETIC THREAD				
	KH Full Gib 7.24 H FA	0396 152814 w/o BC DÜRKOPP-ADLER 296; 396		KH Full Gib 7.24 H FA	1 14 213 ALFA 201-209; 214-217		KH Full Gib 7.24 H FA	153525-4-00 NECCHI 750; 752		KH Full Gib 7.24 H FA	0211 001101 w/o BC DÜRKOPP-ADLER 211; 213; 214; 215; 218
130.05.061			130.05.073			130.05.079			130.05.083		
	KH Full Gib 7.24 H FA	0216 001491 w/o BC DÜRKOPP-ADLER 216		KH Full Gib 7.24 H FA	91 12 00 REFREY 920; 921; 925		KH Full Gib 7.24 H FA	92 12 00 REFREY 920/3; 925/3; 927/3		KH Full Gib 7.94 H FA	32388 SINGER 191D 200 AA; 281; 281-181; 281-183; 281-41; 291U; 391U; 491D
130.05.089			130.05.124			130.05.127	Under trimming mach.		130.05.151		
	KH Short Gib 7.24 H FA	221525-4-00 NECCHI 835; 885; 891-100; SG; SM; UAN-1531		KH Full Gib 7.24 H FA	0396 150814 w/o BC DÜRKOPP-ADLER 396; 550-16-2; 550-16-3		KH Full Gib 7.94 H FA	D1830-555-DAC JUKI ADU-1853; ADU-1854; DDL-555-4; DDL-555-5		KH Full Gib 7.24 H FA	0265 012786 w/o BC DÜRKOPP-ADLER 265; 265-101; 265-15135
130.05.160	With one lubrication channel		130.05.205	Heavy materials		130.05.219	Under trimming mach.		130.05.222		
Code Similar Article 130.05.246	WITH TWO LUBRICATION CHANNELS					Code Similar Article 130.05.477	WITH SHARP HOOK POINT				
	KH Full Gib 7.94 H FB	116780-901 BROTHER DB2-B706-1; DB2-B793-3 B1830-127-OAO JUKI DDL-127; DDL-5530N 143342FG SINGER 191D; 241; 591D 203		KH Full Gib 7.94 H FA	513170 SINGER 770; 771G		KH Full Gib 7.24 H FA	11275-901 NECCHI 835; 885; 891-100; SG; SM; UAN-1531		KH Full Gib 7.24 H FA	0212 052084 w/o BC DÜRKOPP-ADLER 212
130.05.235			130.05.242			130.05.246	With two lubrication channels		130.05.247		
Code Similar Article 130.05.235TS	TS COATED					Code Similar Article 130.05.160	WITH ONE LUBRICATION CHANNEL				
	KH Tacking Gib 7.94 H FB	B1830-555-GAO JUKI DDL-227F; DDL-555G 143342 Tacking gib SINGER 251; 391U; 451K 2110314-310 TOYOTA D 1412-61		KH Tacking Gib 8.10 H FA	61407B UNION SPECIAL 61200; 61400; 63900		KH Short Gib 7.94 H FB	111275-901 BROTHER DB2-B706-5; DB2-B755-5 MF22B0120 MITSUBISHI DB-130-12; LS2-130-HOB 414424 SINGER 241; 251; 400W; 451K		KH Full Gib 7.24 H FA	971911-4-00 NECCHI UAN-2500; UAN-2631; UAN-2641; UAN-2661; UAN-2681; UAN-2682
130.05.250	Oil lubrication screw		130.05.252			130.05.271			130.05.287		
			Code Similar Article 130.05.252TS	TS COATED		Code Similar Article 130.05.517	OPEN TYPE LUBRICATION SYSTEM				



KH	Full Gib	7.24 H	FA	KH	Full Gib	7.24 H	FA	KH	Full Gib	7.24 H	FA	KH	Full Gib	7.24 H	FA	
		0271 000751 w/o BC DÜRKOPP-ADLER 271				0272 001121 w/o BC DÜRKOPP-ADLER 272				0265 012321 w/o BC DÜRKOPP-ADLER 265-115203; 265-18103; 265-203; 265-25407; 265-4103				N2215244 IDEAL 6855		
130.05.311		Under Trimming Mach.		130.05.320				130.05.332				130.05.343				
KH	Full Gib	7.94 H	FB	KH	Full Gib	7.24 H	FA	KH	Full Gib	7.94 H	FB	KH	Full Gib	7.24 H	FA	
		B1830-555-UAO JUKI DDL-555U 143342FG 3 Hub Screw SINGER 241; 251; 281-181; 281-183; 281-41; 400W; 402W; 451K; 600W				0396 150914 w/o BC DÜRKOPP-ADLER 396				110-38650 JUKI DDL-5530 MF40A0120 H style MITSUBISHI LS2-1180-M1T 07-003A-270A SUNSTAR KM-235A; KM-350A-7				8427 0136 ALTIN 8332		
130.05.350		Oil lubrication screw		130.05.369		Heavy materials		130.05.376		Under trimming mach.		130.05.410				
										Code Similar Article 130.05.376DC20						
										DC20 COATED						
KH	Full Gib	7.24 H	FA	KH	Full Gib	7.94 H	FB	KH	Full Gib	7.94 H	FB	KH	Full Gib	7.94 H	FB	
		8427 0171 R235 GLOBAL ZZ-564; ZZ-565-TD 522 980 008 235 MINERVA 72-113-101; 72-113-102				SA1931-001 BROTHER DB2-B738-3; DB2-B774; DB2-B7741; DB2-DD-7100 TYPICAL BROTHER DB2-C201; DB2-C201-3				544784 SINGER 591D 200; 591D 315GA; 591E 200G; 591UX 312; 591V 300 B VI.BE.MAC 591 V300				153131-901 BROTHER BAS-23; DB2-B781-804 MF40A0120 K style MITSUBISHI LS2-1180-L1T 112034010 K Style YAKUMO (NAKAJIMA) 178 Y-2		
130.05.412		Under trimming mach.		130.05.414		Under trimming mach.		130.05.416		Under trimming mach.		130.05.424		Under trimming mach.		
KH	Full Gib	7.94 H	FB	KH	Full Gib	7.94 H	FB	KH	Full Gib	7.94 H	FB	KH	Full Gib	7.94 H	FB	
		D1830-415-BAH DDL-5580H; DLN-415H MF42B0120 MITSUBISHI LS2-1180-H 07-003A-270B SUNSTAR KM-235B; KM-250B-7				MF40A0120 old HIGHLEAD GC 128-M-D3 MITSUBISHI LS2-1180-M1T; LS2-1280-M1T; LS2-180-M; LS2-2210-M				2110904-310 CONSEW 291 RH B1830-555-HAO JUKI DDL-227H; DDL-227L 07-007A-123B SUNSTAR KM-123B; KM-137B				D1830-555-DAB JUKI DLD-436-5; DLN 415-5 MF00A0120 MITSUBISHI LS2-2210-M		
130.05.428		Under trimming mach.		130.05.430		Under trimming mach.		130.05.436				130.05.473		Under trimming mach.		
KH	Full Gib	7.94 H	FA	KH	Full Gib	7.94 H	FA	KH	Short Gib	7.94 H	FB	KH	Short Gib	7.94 H	FB	
		111-41355 G113 JUKI DDL-900SS; DLM-5410N-7 SIRUBA L818F-F1 - Under trimming mach.				111-41355 DC10 JUKI DDL-5550N-7; DDL-900SS; DLD-5430N-7; DLM-5400-6; DLM-5400N-7; DLN-9010SS				G122J GOLDEN WHEEL CS-5100-HL-BT SIRUBA L818F-H1-13 112034020 w/o TS Coated YAKUMO (NAKAJIMA) 178 Y-3				BROTHER DB2-B706-5; DB2-B714-5; DB2-B755-5		
130.05.477		Under trimming mach.; With sharp hook point WITH STANDARD HOOK POINT		130.05.477DC10		Under trimming mach.; With sharp hook point WITH STANDARD HOOK POINT		130.05.479		Under trimming mach.		130.05.481		Extra heavy materials		
		Code Similar Article 130.05.219				Code Similar Article 130.05.219				Code Similar Article 130.05.521						
										OPEN TYPE LUBRICATION SYSTEM						
KH	Full Gib	7.94 H	FB	KH	Full Gib	7.24 H	FA	KH	Full Gib	7.24 H	FA	KH	Full Gib	7.94 H	FA	
		PROTEX (TONGYU) TY-2000-6; TY-6180H TYPICAL GC 6-8A ZOJE ZJ5600N				0271 150124 w/o BC DÜRKOPP-ADLER 271; 271-140331; 271-140332; 271-140342; 272-140331; 272-140332; 272-640642; 272-74642; 273-140342; 275				0271 150034 w/o BC DÜRKOPP-ADLER 271; 271-140432; 271-140442; 273-140432; 275; 550-16-23; 550-16-26				B1830-245-OAO JUKI DSC-244; DSC-244V; DSC-245; DSC-245V B1830-245-OAO- YAKUMO (NAKAJIMA) 381Y; DSC-245		
130.05.492				130.05.494		Under Trimming Mach.		130.05.494DC20		Under Trimming Mach.; DC20 Coated		130.05.496				
						Code Similar Article 130.05.494DC20				Code Similar Article 130.05.494						
						DC20 COATED				STANDARD EXECUTION						
KH	Full Gib	7.94 H	FA	KH	Full Gib	7.94 H	FA	KH	Full Gib	7.94 H	NBL	FB	KH	Short Gib	7.94 H	FB
		91-262 250-91 w/o BC PFAFF 1181; 1183				91-264 300-91 w/o BC GEMSY 9000W-7 PFAFF 1051; 1053; 1181D Oil free; 1183D Oil free				116780-901 BROTHER DB2-B706-1; DB2-B781-1 110-92459 JUKI DDL-127; DDL-5530N SINGER 241; 251; 366				SA1698-001 open type BROTHER DB2-B706-5; DB2-B755-5 MF22B0120 MITSUBISHI LS2-1280-H1TW 414424 open type SINGER 191DX241; 191DX258A		
130.05.500				130.05.507DC20		DC20 coated		130.05.515		Open type lubrication system		130.05.517		Open type lubrication system		
										Code Similar Article 130.05.235				Code Similar Article 130.05.517TS		
										CLOSED TYPE LUBRICATION SYSTEM				TS COATED		































KH	Short Gib	7.94 H	FB	KH	Full Gib	7.94 H	FB	KH	Full Gib	7.94 H	FB	KH	Full Gib	7.94 H	FB
	BAOMA GC158-BD				110-38650 JUKI DDL-555; DDL-5550N-7; DLM-5400-6 07-003A-270A(SPI) SUNSTAR KM-250A-7; KM-250AU				PFAFF 1181; 1183; 3511-2/01; 3701-4/11; 9083				110-92251 JUKI DDL-5530H; DDL-5550H-6; DDL-8700H7WB; DDL-9000SH; DLN-9010SH		
130.05.521	Open type lubrication system, Under trimming M.			130.05.527	Under trimming mach; With sharp hook point			130.05.530				130.05.532	Under trimming mach.		
Code Similar Article 130.05.479	CLOSED TYPE LUBRICATION SYSTEM			Code Similar Article 130.05.376	WITH STANDARD HOOK POINT			Code Similar Article 130.05.500	FA						
KH	Full Gib	7.94 H	FA	KH	Full Gib	7.94 H	FB								
	0281 150104 w/o BC DÜRKOPP-ADLER 281				BD-3292 PFAFF 1163										
130.05.534				130.05.537											
				Code Similar Article 130.05.530	FB W/O LUBRICATION SYSTEM										

**GANCIO ROTATIVO GRANDE CAPACITÀ
LARGE CAPACITY ROTARY HOOK
GROSSRAUM-UMLAUFGREIFER
CROCHET ROTATIF GRANDE CAPACITE
GARFIO ROTATIVO DE GRAN CAPACIDAD
LANÇADEIRA ROTATIVA DE GRANDE CAPACIDADE**

KH	Full Gib	7.94 H	FB	KH	Short Gib	7.94 H	FB	KH	Full Gib	7.94 H	FA	KH	Full Gib	7.94 H	FA
	2120304-310A CONSEW 120 522454 SINGER 121C 330; 121C 330AA 104507000 YAKUMO (NAKAJIMA) DSN-178L-2				K-1830-HBO FOMAX KDD-5570HB MF25B0120 MITSUBISHI CU-865-22FP NITAKA TDY-3812L; TTC-3750				GEMSY GEM 0718; GEM 0818 JUKI DDL-5600 239727 SINGER 121C 330AA; 369				1920 12 00 REFREY 1920; 1922; 1923; 1925; 1927		
130.09.000				130.09.006				130.09.009	Under trimming mach.			130.09.011			
Code Similar Article 130.09.023TS	TS COATED														
KH	Short Gib	7.94 H	FB	KH	Full Gib	7.24 H	FA	KH	Full Gib	7.24 H	FA	KH	Full Gib	7.94 H	FA
	2130104-300B- Short gib CONSEW 175 RB 35574 Short gib MEISTERGRAMM M700XL; M800XL 2130104-300B Short gib TOYOTA D 530-E; D 532				0271 001021 w/o BC DÜRKOPP-ADLER 271				227525-4-00 NECCHI 891-104; 891-264; 895-108; 895-111; 895-266; 895-268; 895-566; 895-568				IE 35872CT IDEAL 6882 NECCHI POCKET SETTER 35872C SEIKO LAH-1LC		
130.09.023				130.09.050				130.09.052				130.09.054			
Code Similar Article 130.09.023TS	TS COATED														
KH	Full Gib	7.94 H	FB	KH	Full Gib	7.94 H	FB	KH	Short Gib	7.94 H	FA	KH	Full Gib	7.94 H	FB
	IE 35822CH IDEAL 6881				159793-901 BROTHER BAS-350; BAS-360 1650-518 SINGER 1650E; 650E 1650-906 V.I.BE.MAC 2650 EV5; 650 EV				135 660 KSM KSM 210 6 385-24 385; KSM 220 6 385-24 385; KSM 230 6 385-24 385				3292990114 RESTA H220-CNK1; H220-CNK2; H220-CNK3; H220-G2; H220-G2L; H220-G3; H220-G3L; H220-G3N; H292		
130.09.059	Heavy materials			130.09.082	Under trimming mach.			130.09.084				130.09.097	FB Special "RESTA"		
				Code Similar Article 130.09.228	SHORT GIB							Code Similar Article 130.09.097L	WITH NOISELESS HOOK SYSTEM PATENT		
KH	Short Gib	7.94 H	FA	KH	Short Gib	7.24 H	FB	KH	Short Gib	7.94 H	FB	KH	Full Gib	7.94 H	FA
	BARUDAN BEAM serie; BEAT serie MEC5050000 TAJIMA TMBE; TME; TMEX; TMFD-C; TMFN; TMFX-IIC, IIIC, IV; TMLE				712 CONSEW 146 RB; 146 RBL 712 SEIKO H-2BL-AE STAGER SZ 21-3BNL; SZ 21-6				18033- CONSEW 206 RB; 206 RB-5; 206 RBL-25 18033 SEIKO SSH-8BLD; SSH-8BLDC; STH-8BL; STH-serie				3292990113 RESTA MILLI; MPUC; MPUS; MPUT		
130.09.103				130.09.115				130.09.123				130.09.143			
Code Similar Article 130.09.103TS	TS COATED											Code Similar Article 130.09.205	FB		



 HB220010 BARUDAN BEAT serie; BENT serie; BESR serie 05022009J016 TAJIMA TFMX; TFMX-II C; TMEX; TMFN; TML; TMLG	 18-10842 J.A.M. TC 125	 0367 156014 w/o BC DÜRKOPP-ADLER 367; 367-170 010; 367-170 115; 367-170 315	 99-136 970-91 DC20 KSM KSM 200; KSM 210; KSM 220; KSM 230 ZOJE FB-200
130.09.150 Under trimming mach.	130.09.152 Under Trimming Mach.; light material	130.09.158 Light materials; For Needles from 120 to 150	130.09.168DC20 DC20 coated
Code Similar Article 130.09.150TS	Code Similar Article 130.09.214	Code Similar Article 130.09.196	
 150487-901 BROTHER DB2-B797-5 18849- CONSEW 205 RB; 278 R-1 B1830-241-SAO JUKI DNU-241HS; DU-580	 JQ6100-0A GOLDEN WHEEL CS-8713V; CSU-4100H B1830-241-HAO JUKI DNU-1541; DNU-261H NITAKA TTC-3750L; YU-380L	 GARUDAN GF-131-446 MH/L	 0891 016041 w/o BC DÜRKOPP-ADLER 8967-160180; 8967-160182
130.09.176	130.09.180 Under trimming mach.	130.09.186 Under trimming mach.	130.09.188
Code Similar Article 130.09.226			
 26010079 IVOMAQ CI 2100 4AV; CI 2100 4AVC	 S35595-901 BROTHER BAS-423; BE-0101B-AC TYPICAL GC 2605; GC 6-9-D3A	 0367 155214 w/o BC DÜRKOPP-ADLER 327-180115; 367; 367-180 310; 367-180 112; 367-180 115; 367-180 315	 3292990114 FB standard RESTA H220-CNK1; H220-CNK2; H220-CNK3; H220-G2; H220-G2L; H220-G3; H220-G3L; H220-G3N
130.09.191	130.09.193 Under trimming mach.	130.09.196 For Needles from 130 to 180: Heavy materials	130.09.205
		Code Similar Article 130.09.158	Code Similar Article 130.09.143
 157853-901 BROTHER BAS-423; DB2-B748-307 GOLDEN WHEEL CS-350L-T; CS-6132BT MG44B0120 MITSUBISHI DY-359-22; DY-359-22BZ	 MF25B0120 MITSUBISHI CU-865-22FP; LS2-130B G131 SIRUBA YF616-X2; YF619-X2 SUNSTAR KM-640BL	 18-10842 FB J.A.M. TC 125	 41020 SEIKO LZ2-990
130.09.207 Under trimming mach.	130.09.210	130.09.214 Under Trimming Mach.	130.09.223
		Code Similar Article 130.09.152	
 147789-901 BROTHER DB2-B745-5; DB2-B746-8 B1830-201-OAO JUKI DDL-201; DDL-5600NL 07-007A-146L SUNSTAR KM-146BL; KM-340BL	 S00982-901 SG BROTHER BAS-350; BAS-360 1650-518 SG SINGER 1650E; 650E 1650-906 SG V.I.BE.MAC 2650 EV5; 650 EV	 18-10842 Heavy material J.A.M. TC 125	 S00688-901 BROTHER KE-484C; LK3-B484
130.09.226 Under trimming mach.	130.09.228 Under trimming mach.	130.09.231 Under Trimming Mach.; Heavy material	130.09.500 3 times large capacity hook; Heavy material
Code Similar Article 130.09.176	Code Similar Article 130.09.082	Code Similar Article 130.09.214	Code Similar Article 130.09.506
 S00689-901 BROTHER KE-484C; LK3-B484	 S44833-001 BROTHER KE-484C; LK3-B484	 SA2036-101 BROTHER KE-484C; KE-484C-X; LK3-B484	 65114 MECA TECHNA MultiTech; TECHNA Unlimitec
130.09.506 3 times large capacity hook; Light-Medium material	130.09.511 3 times large capacity hook; with long hook point	130.09.514 3 times large capacity hook; Extra Heavy material	130.09.516 3 times large capacity hook; For Quilting Machine
Code Similar Article 130.09.500	Code Similar Article 130.09.500	Code Similar Article 130.09.511	Code Similar Article 130.09.521
 65114/CLB MECA TECHNA MultiTech; TECHNA Unlimitec	 J.A.M. MODEL FOR JEANS	 J.A.M. MODEL FOR JEANS	 SOTEXI L2000
130.09.521 3 times large capacity hook; With Coreless Basket	130.09.523 3 times large capacity hook; Heavy material	130.09.529 3 times large capacity hook; Heavy material	130.09.535 3 times large capacity hook; Heavy material
Code Similar Article 130.09.516	Code Similar Article 130.09.529	Code Similar Article 130.09.523	Code Similar Article 130.09.537



KH	Short Gib	7,94 H			KH	Short Gib	7,24 H	FA		KH	Short Gib	7,24 H	FA		KH	Short Gib	7,24 H	FB	
	SOTEXI L2000					91-168 888-91 w/o BC PFAFF 417; 417 (-900/..)A; 417 (-900/..)B; 417-818 A; 417-818 B; 419; 419 (-900/..)A; 910 AB; 917 (-900/..)B; 918 (-900/..)A					95-629 677-91 w/o BC PFAFF 3518; 418-712; 910					95-753 435-91 w/o BC PFAFF 3518; 3518 Multidirectional sewing			
130.09.537	3 times large capacity hook; With Coreless Basket				130.23.000	Under Trimming Mach.				130.23.009	Under Trimming Mach.				130.23.013	Multidirectional sewing			
Code Similar Article 130.09.535	STANDARD BASKET VER.																		
KH	Short Gib	7,24 H	FA		KH	Short Gib	7,24 H	FA		KH	Short Gib	7,24 H	FA		KK	Short Gib	6,35	--	FB
	91-167 980-91 w/o BC PFAFF 417 (-900/..)C; 418 (-900/..)C; 418 C					91-167 082-91 w/o BC PFAFF 3568; 3568-12/11; 3568-2/01; 3568-2/11; 910					91-268 093-91 w/o BC PFAFF 910-Homemaker ver.; 918-Homemaker ver.					642022050 BARATTO 158 Serie			
130.23.015	Under Trimming Mach.				130.23.050					130.23.052					130.30.100	Scalping machine			
					Code Similar Article 130.00.351	COMPLETE KK HOOK WITH BC				Code Similar Article 130.00.352	COMPLETE KK HOOK WITH BC								

GANCIO ROTATIVO VERTICALE
VERTICAL ROTARY HOOK
VERTIKAL-UMLAUFGREIFER
CROCHET ROTATIF VERTICAL
GARFIO ROTATIVO VERTICAL
LANÇADEIRA ROTATIVA VERTICAL

KK	Full Gib	7,92	--		KK	Short Gib	7,92	--		KK	Short Gib	7,92	--		KK	Full Gib	7,92	--	
	91-010 165-91 PFAFF 120; 122; 142 A; 142 B; 145-H3 B; 191; 192 A; 192 B; 196-H3 B; 240/290 AB; 240/290 S; 242-720/02 (1,6-7,6); 292 B; 9491; 9493					26010001 IVOMAQ CI 3000-11; CI 3000-201DI; MITT 4000; MITT 4000-202RT; MITT 4000-202RTE; MITT 4400-2RTA2; MITT 4400-2RTFA1					91-010 850-91 PFAFF 142 C; 142 D; 143-705/03 C; 192 C; 193 C; 194 C; 194-944/01 C; 195-H3 C; 195-H3 D; 196-H3 C; 196-H3 D; 290; 292 C					91-010 896-91 PFAFF 142 A; 142 B; 194-720/02; 194-944/01; 194-944/01 B; 195-H3 B; 195-H3 C; 240; 290; 292 B; 292 BN; 294; 832 B; 893 A; 893 L; 9493			
130.08.000					130.08.050					130.08.054	Heavy materials			130.08.304					
KK	Full Gib	7,92	--		KK	Full Gib	7,92	--		KK	Full Gib	7,92	--		KK	Short Gib	7,92	--	
	91-019 922-91 PFAFF 120; 122; 142-721/01 Needles distance from 8mm; 192-721/01 Needles distance from 8mm; 242-720/02 (8,0-30,0)					26010043 IVOMAQ MITT 4000-202RD 91-119 386-91 PFAFF 470; 471 A; 490 AB SEIKO GPB-8W					0068 150824 DÜRKOPP-ADLER 67; 68					0068 150814 DÜRKOPP-ADLER 67; 68			
130.08.314					130.08.319	For Europe market; Light material				130.08.341				130.08.343	Heavy materials				
					Code Similar Article 130.08.900	FOR ASIA MARKET				Code Similar Article 130.08.343	FOR HEAVY MATERIALS			Code Similar Article 130.08.341	FOR LIGHT MATERIALS				
KK	Full Gib	7,915	--		KK	Full Gib	7,915	--		KK	Short Gib	7,915	--		KK	Short Gib	8,00	--	
	204524-6-00 NECCHI 951-260; 951-460; 953; 971					205524-6-00 NECCHI 927-103; 927-203; 927-263; 980					207524-6-00 NECCHI 960; 961; 980					971312-6-02 NECCHI 902-155; 931-100; 931-101; 932-100			
130.08.356	Under trimming mach.				130.08.370	Under trimming mach.				130.08.374	Under trimming Mach.			130.08.384					
KK	Short Gib	8,00	--		KK	Short Gib	8,00	--		KK	Short Gib	7,92	--		KK	Full Gib	7,92	NBL	
	971735-6-02 NECCHI 925-103; 925-403					114524-6-02 NECCHI 910-113; 910-158; 910-159; 911-113; 930-113; 930-159					91-119 767-91 PFAFF 470; 471 B; 471 C; 474 B/C; 491 B/C; 493 B/C					91-113 414-91 PFAFF 140; 140-900; 141-900/..; 141-900/06; 144-900/..; 145-900/06; 146-900/06; 240; 242-720/02-900/..			
130.08.394					130.08.405					130.08.451	For Europe market; Heavy material			130.08.456	Under trimming mach.				
										Code Similar Article 130.08.904	FOR ASIA MARKET								



 <p>91-113 190-91 PFAFF 142-900/..; 144-900/06; 145-900/06; 146-900/06</p>	 <p>901 12 00/41 REFREY 901/41; 902/41</p>	 <p>10165/1 CIUCANI MC-747; MC-88; MC-89; MC-99 26010081 IVOMAQ CI 5000</p>	 <p>901 12 00 REFREY 901; 902</p>
130.08.462	Under trimming mach.	130.08.470	Under trimming mach.
130.08.478		130.08.482	
			Code Similar Article 130.08.591 FULL GIB
 <p>05 17 0016 ATTILIO FORTE AF 8 CF; AF 8 CFEL; AF 8 CFELCA; AF 8.2 CF</p>	 <p>207524-6-10 NECCHI 961</p>	 <p>204524-6-10 CONSEW 701 ATC NECCHI 953; 971; 974</p>	 <p>205524-6-10 NECCHI 974</p>
130.08.497		130.08.501	
		130.08.507	Under Trimming Mach.
		130.08.511	Under Trimming Mach.
 <p>971921-6-00 NECCHI 960; 961; 962; 963; 964; 980; 981; 982; 983</p>	 <p>91-119 385-91 PFAFF 1491 (E)-900/.. B; 3834-3/11; 3834-4/11; 470; 471-900/.. A; 471-900/.. B; 474-900/.. A; 490-900 AB; 491-900/.. A; 491-900/.. B</p>	 <p>91-119 899-91 PFAFF 1491 (E)-900/.. B/C; 1493 (E)-900/.. B/C; 470; 471-900/.. B; 471-900/.. C; 474-900/.. B/C; 490-900 CD; 491-900/.. B/C; 493-900/.. B/C</p>	 <p>91-012 781-91 PFAFF 194-900/56 A; 290-900 A; 294-720/02-944/01 B; 294-720/02-944/01 B/C; 294-900/.. B; 294-900/.. C; 294-944/01 A; 294-944/01 B</p>
130.08.515		130.08.518	Under trimming mach.
		130.08.524	Under trimming mach.
		130.08.530	Under trimming mach.
			Code Similar Article 130.08.973 SHORT GIB
 <p>91-118 875-91 PFAFF 440 AB; 440 L; 441-0; 441-R; 442-0; 442-R; 444 A; 444 B; 444-0; 444-R; 448-0; 457-0</p>	 <p>91-118 876-91 PFAFF 140 AB; 440 S; 441-0; 442; 442-0; 442-720/04; 442-R; 444 A; 444 B; 444-0; 444-R; 448-0; 457-0</p>	 <p>91-118 419-91 PFAFF 440-900 Leder; 441-0-900; 442-0-900/..; 444-0-900/..; 444-900/.. A; 444-900/.. B; 444-R-900/..; 448-0-900/..; 457-0-900/..</p>	 <p>91-118 318-91 PFAFF 440-900; 441-0-900; 142-900/11; 442-R-900/11; 442-R-900/51; 442-R-900/71; 444-R-900/..; 448-0-900/..; 457-0-900/..</p>
130.08.534	Heavy materials	130.08.537	Light materials
Code Similar Article 130.08.537	LIGHT MATERIALS	Code Similar Article 130.08.534	HEAVY MATERIALS
		130.08.540	Heavy materials; Under trimming mach.
		130.08.546	Under trimming mach.; Light materials
			Code Similar Article 130.08.540 HEAVY MATERIALS
 <p>91-140 454-91 PFAFF 240 AB; 241; 242; 244(-720/02); 245; 246</p>	 <p>91-140 543-91 PFAFF 241; 242; 244(-720/02); 245</p>	 <p>91-140 544-91 PFAFF 241-900; 242-900/..; 244 (-720/02)-900/..; 245-900/..; 246-900/..; 290-900</p>	 <p>91-140 545-91 PFAFF 244-900/..; 290-900</p>
130.08.548		130.08.553	
Code Similar Article 130.08.553	SHORT GIB	Code Similar Article 130.08.548	FULL GIB
		130.08.556	Under trimming mach.
		130.08.558	Heavy materials; Under trimming mach.
			Code Similar Article 130.08.556 FULL GIB
 <p>91-014 192-91 PFAFF 340; 341-6A; 341-6B; 345-6; 345-H3</p>	 <p>GP-406 GARUDAN GP-406-149; GP-410-146; GP-410-149; GP-414-149</p>	 <p>105 49855 JUKI PLW-1246-4; PLW-1246-6 37735 SEIKO PWB-22GWC; PWB-8GWC; PWB-8GWC-LC</p>	 <p>91-173 240-91 PFAFF 440-900 AB; 441-R-900/..; 442-720/04-900/..; 442-R-900/56; 442-R-900/61</p>
130.08.560	Light material	130.08.578	Under trimming mach.; with star-NBL
Code Similar Article 130.08.912	SHORT GIB	Code Similar Article 130.08.907	WITH STANDARD NBL
		130.08.580	Under trimming mach.
		130.08.585	Under Trimming. Mach.
			Code Similar Article 130.08.594 SHORT GIB
 <p>GP-402 GARUDAN GP-401-101; GP-402-101; GP-410-141; GP-410-143; GP-410-144; GP-414-141; GP-420-101; GP-424-101</p>	 <p>901 12 00-P REFREY 901; 902</p>	 <p>JAB6100-0A GOLDEN WHEEL CS-6111B; CS-6111T; CS-6112B; CS-6112BFT SUNSTAR KM-857-7; KM-867-7; KM-875-7</p>	 <p>37255 SEIKO GPB-8W; PWB-8W TYPICAL GC 24660; GC 24680 116728000 YAKUMO (NAKAJIMA) 561; 562; 563; 564</p>
130.08.588		130.08.591	
		Code Similar Article 130.08.482	SHORT GIB
		130.08.594	Under trimming mach.
			Code Similar Article 130.08.580 FULL GIB
		130.08.900	For Asia market; Light material
			Code Similar Article 130.08.319 FOR EUROPE MARKET



 <p>JJ6100-1A GOLDEN WHEEL CS-8810; CS-8820 37256 SEIKO PWB-8GW; PWB-8GW-1 G152-A SIRUBA R718-02; R728; R728-</p>	 <p>G-400T GARUDAN GP-406-149; GP-410-146; GP-410-149; GP-414-149</p>	 <p>26010190 IVOMAQ MITT 4000; MITT 4000-202RDC; MITT 4000-202RTC; MITT 4000-202RTCA</p>	 <p>PFAFF 341-6A; 341-6B; 345-6; 345-H3</p>
130.08.904	130.08.907	130.08.909	130.08.912
Code Similar Article 130.08.451	Code Similar Article 130.08.578		Code Similar Article 130.08.560
For Asia market; Heavy material FOR EUROPE MARKET	Under trimming mach.; With standard NBL WITH STAR-NBL	Under trimming mach.	Heavy Materials FULL GIB
 <p>IVOMAQ MITT 4000; MITT 4000-202RDC; MITT 4000-202RTC; MITT 4000-202RTCA</p>	 <p>GOLDEN WHEEL CS-8360; CS-8820H 14119 W/Cap SEIKO LHPW-8B-1 G153-A SIRUBA R718-01H; R728-__H</p>	 <p>91-263 430-91 PFAFF 571 A; 571 B; 574 A; 574 B; 574-725/04 A; 574-725/04 B; 594 A; 594 B; 594-725/04 A</p>	 <p>91-263 435-91 PFAFF 571 C; 574 C; 574-725/04 C C; 594 C; 594-725/04 C</p>
130.08.915	130.08.919	130.08.934	130.08.946
Under trimming mach.	Code Similar Article 130.08.904	Under Trimming Mach.	Under Trimming Mach.
	Extra heavy materials HEAVY MATERIALS		
 <p>91-164 900-91 PFAFF 421; 421-900/61-B; 421-900/61-C; 421-900/61-G</p>	 <p>91-166 733-91 PFAFF 422; 422-720/..; 422-900/..</p>	 <p>91-014 415-91 PFAFF 343-712; 343-712/..; 343-G; 343U; 344U</p>	 <p>MILLION SPECIAL MS-474-510; MS-474-530; MS-491-810; MS-491-830; MS-674-530; MS-674-530P; MS-691-810; MS-691-830; MS-691-830P</p>
130.08.950	130.08.960	130.08.965	130.08.970
Under trimming mach.	Under trimming mach.		Under trimming mach.
 <p>91-012 782-91 PFAFF 294-944/01 C</p>	 <p>10655 CONSEW 139; 226; 237 10655 SEIKO STW-8V; STW-8VM 240558 SINGER 111W 156; 211U 165</p>	 <p>244711 GEMSY 2000-1 SINGER 211GX 115; 212A 147; 212GX 110; 212GX 115; 212U 41</p>	 <p>240207 SINGER 111W 100; 111W 102; 111W 103; 111W 113; 111W 153; 111W 154</p>
130.08.973	130.11.000	130.11.016	130.11.045
Under trimming mach.			
Code Similar Article 130.08.530			
FULL GIB			
 <p>248463 SINGER 112W 140; 112W 145; 112W 146</p>	 <p>240240 SINGER 111W 150; 111W 151</p>	 <p>240091 SINGER 112W 110; 112W 115-139</p>	 <p>B1830-051-OAO JUKI LH-51; LH-51-10; LH-516; LH-517; LH-518; LU-53-7; LU-562A 237204 SINGER 112W 115-139</p>
130.11.051	130.11.057	130.11.060	130.11.062
 <p>12032 CONSEW 289; 289 R-1; 382 R-1 GOLDEN WHEEL CS-8BH 238250 SINGER 153K; 153W</p>	 <p>29474 AC UNION SPECIAL 61800; 62200</p>	 <p>BAOMA GC2018; GC2318 NITAKA TC-810; TC-820 12032 SEIKO LPW-6B; PW-6; PW-7 With forked tension spring</p>	 <p>13086 CONSEW 207; 382; 388 HIGHLEAD GC 24698-1L 13086 SEIKO CW (ALL CLASSES)</p>
130.11.065	130.11.068	130.11.075	130.11.076
Code Similar Article 130.11.075		Code Similar Article 130.11.065	
WITH FORKED TENSION SPRING		WITH NOT FORKED TENSION SPRING	
 <p>112691-901 BROTHER LT2-B831-1; LT2-B831-3 15875 CONSEW 332; 332 R; 332 R-1 JC6100-4A GOLDEN WHEEL CS-3100-3; CS-872-3</p>	 <p>GOLDEN WHEEL CS-7162; CS-7162S MN10A0120 MITSUBISHI LT2-2220-MOB 554507 SINGER 211A 157JA; 312U; 412U</p>	 <p>101-95154 JUKI LH-1152-4; LH-1152-5; LH-1152-6; LH-1152-7</p>	 <p>B1830-512-OAO JUKI LH-512; LH-512-3; LH-515 SHANGGONG GC15-5-4D; GD9; GDB</p>
130.11.078	130.11.084	130.11.090	130.11.101
		Under trimming mach.	







KL	Short Gib	8.00 H		KL	Full Gib	9.52		KL	Full Gib	9.52		KL	Full Gib	9.52	
	<u>B1830-512-OAH</u> JUKI LH-512H; LH-515H				<u>144903-901</u> BROTHER LT2-B831-5 <u>JC6100-010A</u> GOLDEN WHEEL CS-3100-3; CS-872-3 JACK (FEIQIU) JK 5842-5; JK 5842D-3				<u>SA1669-011</u> BROTHER LT2-B841-5; LT2-B842-5 <u>G167</u> SIRUBA T828-42-___HL ZOJE 842-5; ZJ842-5				<u>S07426-901</u> BROTHER LT2-B841-5; LT2-B842-5 PROTEX (TONGYU) TY-B842-5 TYPICAL GC 6842H		
130.11.105				130.11.116				130.11.122	With special hard treatment			130.11.131			
								Code Similar Article 130.11.131	STANDARD EXECUTION			Code Similar Article 130.11.122	WITH SPECIAL HARD TREATMENT		
KL	Full Gib	9.52		KL	Full Gib	7.94		KL	Short Gib	7.94		KL	Short Gib	7.94	
	FOMAX KDD2-1152 <u>101-97655</u> JUKI LH-1150; LH-1152				<u>MV01A0120</u> mitsubishi LS5-5110; LS5-5110-MOB; LS5-5120; LS5-5120-MOB; PB-810; PB-810-10; PB-840-10; PN-840; PN-840-10FP				<u>203804</u> SINGER 212W; 21W 110K; 21W 110W 124; 21W 110W 128; 21W 162				<u>JA6100-1A</u> GOLDEN WHEEL CS-810; CS-821; CS-822 <u>210-10251</u> JUKI PLH 983; PLH 984 <u>116072001</u> YAKUMO (NAKAJIMA) 981; 982; PLN-985		
130.11.135				130.11.155				130.11.160				130.11.165			
												Code Similar Article 130.11.165R	REGULATING NEEDLE GUARD		
KL	Full Gib	7.94		KL	Full Gib	7.94		KL	Full Gib	7.94		KL	Full Gib	9.52	
	<u>R190</u> GLOBAL .F-344; LP-943-R; LP-944; LP-951-7; LP-952 <u>522 980 008 190</u> MINERVA 72-125-104; 72-415-101				<u>R290</u> GLOBAL LF-361-TD; LP-951-TD; LP-971-AUT; LP-971-TD <u>522 980 008 290</u> MINERVA 72-125-105; 72-401-105; 72-411-105; 72-414-107				<u>12530-</u> CONSEW 357 R-1; 358 R-1 <u>12530</u> SEIKO LPW-26; LPW-27 UNICORN LT5-HP331; LT5-HP333				<u>SA1668-011</u> BROTHER LT2-B847; LT2-B847-1 <u>G161</u> SIRUBA T828-41-___LL; T828-41-___ML		
130.11.170				130.11.180	Under trimming mach.			130.11.187				130.11.188	With special hard treatment		
												Code Similar Article 130.11.216	STANDARD EXECUTION		
KL	Full Gib	9.52		KL	Full Gib	9.52		KL	Short Gib	7.94		KL	Full Gib	9.52	
	<u>SA1677-011</u> BROTHER LT2-B842; LT2-B842-403 MILLION SPECIAL MS-B842-403 <u>G163</u> SIRUBA T828-42-LL-U				<u>151016-901</u> BROTHER LT2-B831; LT2-B832; LT2-B832-3-0; LT2-B832-401; LT2-B832-403; LT2-B832-5				GOLDEN WHEEL CS-3610; CS-8BH MITSUTOMO MT-810; MT-820 <u>11075</u> SEIKO LPW-6B; LPW-7B				<u>S07425-901</u> BROTHER LT2-B841; TN-842A-00F <u>226-12055</u> JUKI LH-3120; LH-3128 <u>07-053A-7500</u> SUNSTAR KM-750		
130.11.195	With special hard treatment; Under trimming mach.			130.11.201				130.11.205	Extra heavy materials			130.11.216			
Code Similar Article 130.11.219	STANDARD EXECUTION							Code Similar Article 130.11.075	HEAVY MATERIALS			Code Similar Article 130.11.188	WITH SPECIAL HARD TREATMENT		
KL	Full Gib	9.52		KL	Full Gib	7.93		KL	Full Gib	7.93		KK	Full Gib	7.93	--
	<u>S07427-901</u> BROTHER LT2-B842; TN-842B-403 <u>07-051A-7507</u> SUNSTAR KM-750-7 TYPICAL GC 6842MD4				<u>0249 000592 K</u> DÜRKOPP-ADLER 245				<u>0249 000616 K</u> DÜRKOPP-ADLER 239-105; 239-106; 239-115; 239-116; 239-125; 239-126; 239-135; 241-15; 241-16; 241-5; 245-30				<u>0249 000861</u> DÜRKOPP-ADLER 228; 238; 239; 241; 247; 249		
130.11.219	Under trimming mach.			130.13.100				130.13.115				130.13.122			
Code Similar Article 130.11.195	WITH SPECIAL HARD TREATMENT														
KK	Full Gib	7.93	NBL	KK	Full Gib	7.93	--	KK	Full Gib	7.93	--	KK	Full Gib	7.93	NBL
	<u>0238 006781</u> DÜRKOPP-ADLER 238-line 15000; 239-line 13000; 249-line 13000; 372-line 13000; 376-line 13000; 376-line 15000; 380-line 13000				<u>0380 000492</u> DÜRKOPP-ADLER 372; 376; 380				<u>0380 000493</u> DÜRKOPP-ADLER 372-105; 372-115; 372-116; 372-505; 376-line 15000; 380-15535; 380-585; 380-line 15305				<u>0380 0008104</u> DÜRKOPP-ADLER 249-13315; 249-15315; 372-13303; 372-15303; 380-13305; 380-13335; 541-15503; 697-6155		
130.13.134	Under trimming mach.			130.13.142				130.13.146				130.13.157	Under trimming mach.		
KK	Full Gib	7.93	--	KK	Full Gib	7.93	--	KK	Full Gib	7.93	NBL	KK	Short Gib	7.93	--
	<u>0549 001491</u> DÜRKOPP-ADLER 541; 542; 547; 548; 697				<u>0697 004331</u> DÜRKOPP-ADLER 697-15155; 697-24155				<u>0381 150204 DC20</u> DÜRKOPP-ADLER 381-160161; 381-160162; 382-160162				<u>0697 004331 SP</u> DÜRKOPP-ADLER 697-15155; 697-24155		
130.13.161				130.13.165	Under trimming mach.			130.13.173DC20	DC20 coated; Under trimming mach.			130.13.185	Under trimming mach.		
				Code Similar Article 130.13.185	SHORT GIB							Code Similar Article 130.13.165	FULL GIB		



	150371-901 BROTHER LT2-B835-3; LT2-B835-5 JD6100-5A GOLDEN WHEEL CS-875-3; CS-875-5 16291 SEIKO LTW-27BK	KH	Full Gib	9.52			12355 GOLDEN WHEEL CS-7165-BT; CS-7165S-BT MN50E0120 MITSUBISHI LT2-2250-M; LT2-230-M1TW	KH	Full Gib	9.52			101-10104 JUKI LH-1150; LH-1152	KH	Full Gib	9.52			101-10054 w/o Cap JUKI LH-1150-4; LH-1150-5; LH-1150-6; LH-1152-4; LH-1152-5; LH-1152-6; LH-1152-7	
130.16.000						130.16.005						130.16.010						130.16.015	Under trimming mach.	
	264161 w/o Cap SINGER 136W; 138G 102; 138W 102; 52K; 52W 22	KH	Short Gib	7.94			249118 w/o Cap SEIKO SPW-26; SPW-6 SINGER 136W	KH	Full Gib	7.94			263464 w/o Cap SINGER 236G; 236G 120; 236G 124; 236G 125; 236G 130; 236G 131; 236G 132; 236W	KH	Full Gib	7.94			235797 w/o Cap SINGER 118W; 138W	
130.16.020						130.16.025						130.16.028						130.16.045		
																			Code Similar Article 130.16.063	WITH SPECIAL WASHER NEEDLE GUARD
	412433 w/o Cap SINGER 212U 143; 212U 143A; 212U 144; 212U 443A; 212U 444	KH	Full Gib	8.00 H			JC6100-033A GOLDEN WHEEL CS-3150-5; CS-875-5	KH	Short Gib	9.52			SA1681-011 w/o Cap SINGER LT2-B845; LT2-B845-3 G169 SIRUBA T828-45-___H ZOJE 845; ZJ842-D3	KH	Full Gib	9.52			S13613-901 BROTHER LT2-B845; LT2-B845-3 226-88253 w/o Cap JUKI LH-3168 TYPICAL GC 6845; GC 6845H	
130.16.050						130.16.051						130.16.052	With special hard treatment					130.16.053		
												Code Similar Article 130.16.053	STANDARD EXECUTION					Code Similar Article 130.16.052	WITH SPECIAL HARD TREATMENT	
	SA1670-011 w/o Cap SINGER LT2-B841; LT2-B847 G162 SIRUBA T828-41-___; T828-42-___; T828-47-___	KH	Full Gib	9.52			SA1670-111 w/o Cap BROTHER LT2-B841-1; LT2-B847 226-12758 w/o Cap JUKI LH-3128 SIRUBA T828-42-___	KH	Full Gib	9.52			SA1683-011 w/o Cap SINGER LT2-B845; LT2-B845-907 TYPICAL GC 6845XHD4 WANPING 845; TW2-B845-905	KH	Full Gib	9.52			LT2-B845-907 BROTHER LT2-B845-907; LT2-B848 07-056A-7907 SUNSTAR KM-790-7 TYPICAL GC 6845HD3	
130.16.054	With special hard treatment					130.16.055						130.16.056	With special hard treatment; Under trimming mach.					130.16.059	Under trimming mach.	
Code Similar Article 130.16.055	STANDARD EXECUTION					Code Similar Article 130.16.054	WITH SPECIAL HARD TREATMENT					Code Similar Article 130.16.059	STANDARD EXECUTION					Code Similar Article 130.16.056	WITH SPECIAL HARD TREATMENT	
	SA1678-011 w/o Cap SINGER LT2-B842; LT2-B842-403 G164 SIRUBA T828-42-U; T828-47-___ ___/_ Under trimming mach.; T828-47-U	KH	Full Gib	9.52			S13612-901 BROTHER LT2-B842; LT2-B842-403; LT2-B847-401; LT2-B847-901 TYPICAL GC 6842HD4	KH	Full Gib	9.52			MN25A0120 MILLION SPECIAL MS-B845; MS-B845-5 MITSUBISHI DB-286; LT2-2240-MOB 281081 SINGER 212A 143	KH	Full Gib	9.52			C06217 w/o Cap CORNELY 10; 12	
130.16.060	Under trimming mach.; With special hard treatment					130.16.061	Under trimming mach.					130.16.062						130.16.063		
Code Similar Article 130.16.061	STANDARD EXECUTION					Code Similar Article 130.16.060	WITH SPECIAL HARD TREATMENT											Code Similar Article 130.16.045	W/O WASHER NEEDLE GUARD	

GANCIO ROTATIVO VERTICALE GRANDE CAPACITÀ
LARGE CAPACITY VERTICAL ROTARY HOOK
GROSSRAUM VERTIKAL-UMLAUFGREIFER
CROCHET ROTATIF VERTICAL GRANDE CAPACITE
GARFIO ROTATIVO VERTICAL DE GRAN CAPACIDAD
LANÇADEIRA ROTATIVA VERTICAL DE GRANDE CAPACIDADE

	91-018 340-91 GARUDAN GP-410-444 PFAFF 541 C; 541 D TAKING TK-545; TK-546	KK	Short Gib	7.92	--		91-018 876-91 PFAFF 544-720/02 (8.5-15.2)	KK	Short Gib	7.92	--		91725-6-03 NECCHI 910-114; 916-114; 917-114; 930-114; 955-114; 956; 957-114; 976	KK	Short Gib	7.915			971724-6-01 NECCHI 955-110; 956-100; 957-100; 957-101; 957-107; 957-108; 976; 977-100; 977-101
130.08.100						130.08.130						130.08.174						130.08.180	































 KK Full Gib 7.915 971840-6-01 NECCHI 925-101; 925-401 130.08.182	 KK Full Gib 7.915 971724-6-11 NECCHI 955-260; 955-261; 955-264; 955-461; 956; 956-260; 957-460; 957-461; 977-260; 977-261; 977-460; 977-461 130.08.186	 KK Short Gib 7.915 971907-6-01 NECCHI 955-264; 955-464; 956; 956-264; 957-464; 975-464; 976; 977-264; 977-464 130.08.197	 KK Full Gib 7.915 971840-6-11 NECCHI 928-101; 928-201; 928-261 130.08.203
 KK Short Gib 7.94 -- 0167 001814 DÜRKOPP-ADLER 167; 168; 267; 268 PEMA 286 130.08.240 Code Similar Article 130.08.751R REGULATING NEEDLE GUARD	 KK Full Gib 7.915 971914-6-00 NECCHI 955-110; 955-260; 955-261; 955-264; 955-560; 957; 975-110; 975-260; 975-560; 977 130.08.248	 KK Short Gib 7.915 971989-6-00 NECCHI 955-561; 955-564; 967; 968; 975; 975-111; 975-261; 975-561; 975-564; 976; 978; 985; 987; 988 130.08.254	 KK Short Gib 7.915 971915-6-00 NECCHI 928; 979 130.08.257
 KK Short Gib 7.92 1901 12 00/41 REFREY 1901/41; 1902/41 130.08.261 Under trimming mach.	 KK Short Gib 7.92 1901 12 00 REFREY 1901; 1902 130.08.269	 KK Full Gib 7.92 NBL MILLION SPECIAL MS-1245 91-140 538-91 PFAFF 1240; 1241 B; 1241 B/C; 1245 B; 144 B; 144 C; 1441 B; 1445 B; 1446 B 130.08.273 Code Similar Article 130.08.280 SHORT GIB	 KK Short Gib 7.92 NBL MILLION SPECIAL MS-1245 91-140 539-91 PFAFF 1243; 1245; 1245 C 130.08.280 Code Similar Article 130.08.294 FOR THREAD BIGGER THAN 1MM TYPICAL TW1-1245
 KK Full Gib 7.92 NBL 91-140 541-91 PFAFF 1241-900/.. C; 1246-720/.. (8-30,0) 130.08.283	 KK Short Gib 7.92 NBL 91-140 542-91 PFAFF 1241-900/.. C; 1246-720/.. (8-30,0) 130.08.288	 KK Short Gib 7.92 NBL 91-140 539-91 Heavy duty PFAFF 1243 Mod.for Heavy Thread; 1245 Mod.for Heavy Thread WANPING TW1-1245 Mod.for Heavy Thread 130.08.294 Heavy materials; For thread bigger than 1mm diameter STANDARD EXECUTION Code Similar Article 130.08.280	 KK Full Gib 7.94 -- 0167 150084 DÜRKOPP-ADLER 167; 168; 267; 268 130.08.638
 KK Short Gib 7.94 NBL 0167 150204 DÜRKOPP-ADLER 167FA; 267FA 130.08.642 Under trimming mach.	 KK Full Gib 7.94 NBL 0167 150214 DÜRKOPP-ADLER 167FA; 267FA 130.08.648 Under trimming mach.	 KK Short Gib 7.94 0167 150304 DÜRKOPP-ADLER 267LS-263NH1 130.08.650 Code Similar Article 130.08.800R REGULATING NEEDLE GUARD	 KK Short Gib 7.94 NBL 0268 150174 DÜRKOPP-ADLER 268FA 130.08.658 Under trimming mach. Code Similar Article 130.08.785R REGULATING NEEDLE GUARD
 KK Short Gib 7.92 NBL 91-176 369-91 PFAFF 1440 130.08.660 Under trimming mach.	 KK Full Gib 7.94 NBL 0268 150184 DÜRKOPP-ADLER 268FA 130.08.661 Under trimming mach.	 KK Short Gib 7.94 -- 0169 001814 DÜRKOPP-ADLER 169; 269 130.08.662 Code Similar Article 130.08.787R REGULATING NEEDLE GUARD	 KK Full Gib 7.92 91-018 112-91 PFAFF 1242-720B/C (3,2-7,6); 1244-720/02 130.08.667
 KK Short Gib 7.92 NBL 91-018 680-91 PFAFF 1240 C; 1244-900/.. C/D; 541-900/11; 541-900/16 C; 542-900/.. C; 543-900/.. 544-900/.. C; 544-900/.. C/D; 546-900/.. C 130.08.670 Under trimming mach.	 KK Full Gib 7.92 NBL 91-018 113-91 PFAFF 1240; 1244-900 (720) B/C; 540; 541-900/11; 541-900/16 B/C; 544-720/900/B/C; 544-900/16; 544-900/56 B/C 130.08.676 Under trimming mach.	 KK Full Gib 7.92 NBL 91-140 540-91 PFAFF 1240-900 AB; 1241-900/.. B; 1241-900/.. B/C; 1245-900/.. B; 1246-900/.. B; 1246-900/.. B/C; 3802; 3826-2/01 130.08.678 Under trimming mach.	 KK Short Gib 7.92 NBL 91-140 451-91 PFAFF 1240-900 CD; 1242-900/.. C; 1243-900/.. 1244-900/.. C; 1245-900/.. C; 1246-900/.. C 130.08.680 Under trimming mach.



	KK	Short Gib	7.94	NBL	<i>05 17 0009</i> ATTILIO FORTE AF 8 CF; AF 8 EL; AF 8 LG		KK	Short Gib	7.92	NBL	<i>05 17 0007</i> ATTILIO FORTE AF 8 CF; AF 8 EL; AF 8 LG		KK	Short Gib	7.92	NBL	<i>91-018 285-91</i> PIFAFF 1290-900 CD; 1291-900/.. C; 1293-900/.. C; 1294-900/..; 1294-944/01 C; 1295-900/.. C; 1296-900/.. C; 594-900/56-900/01		KK	Full Gib	7.92	NBL	<i>91-018 482-91</i> PIFAFF 1240; 1242-720/B (3,2-7,6); 1290; 1296 B; 1296-237/06; 541 B; 546-H2-748/01 B			
130.08.682		Under trimming mach.				130.08.688		Under trimming mach.				130.08.697		Under trimming mach.			130.08.703									
	KK	Full Gib	7.92	NBL	<i>91-018 284-91</i> PIFAFF 1290-900; 1291-900/.. B; 1295-900/.. B; 1296-237/06-900/..; 1296-900/.. B; 1297-900/.. B		KK	Short Gib	7.92	NBL	GARUDAN GP-410-446; GP-410-449		KK	Short Gib	7.94		<i>0267 151824</i> DÜRKOPP-ADLER 167; 168; 267; 268 <i>230-28053 R</i> JUKI PLC-1660L; PLC-1760L		KK	Short Gib	7.94		<i>212-28051 W/Cap</i> JUKI LS-321; LS-341 NITAKA TC-360L; TC-8872 <i>122089006</i> YAKUMO (NAKAJIMA) 321L; 341L			
130.08.707		Under trimming mach.				130.08.748		Under trimming mach.				130.08.751R		Regulating needle guard			130.08.758									
														Code Similar Article 130.08.240		STANDARD EXECUTION										
	KK	Short Gib	7.94		GOLDEN WHEEL CS-8233NR; CS-8243NR <i>212-29752 W/Cap</i> JUKI LS-1342; LS-341N NITAKA TC-1341		KK	Full Gib	7.94		<i>212-45154</i> JUKI LS-1341; LS-1342		KK	Short Gib	7.94		<i>0268 150744</i> DÜRKOPP-ADLER 268FA <i>230-25059 R</i> JUKI PLC-1610-7; PLC-1660-7; PLC-1710-7; PLC-1760-7		KK	Short Gib	7.94		<i>0269 150054</i> DÜRKOPP-ADLER 169; 269			
130.08.776						130.08.780						130.08.785R		Under trimming mach.; Regulating needle guard			130.08.787R				Regulating needle guard					
		Code Similar Article 130.08.776R			REGULATING NEEDLE GUARD									Code Similar Article 130.08.658		STANDARD EXECUTION						Code Similar Article 130.08.662		STANDARD EXECUTION		
	KK	Full Gib	7.94		<i>212-45055 W/CAP</i> JUKI LS-321		KK	Short Gib	7.94		DÜRKOPP-ADLER 268 Mod.for Heavy Thread <i>26010196</i> IVOMAQ CI 3000; MITT 4400 JUKI PLC-1660L; PLC-1760L		KK	Short Gib	7.94		<i>0267 151834</i> DÜRKOPP-ADLER 267LS-263NH1 <i>230-29051 Reg.needle gua</i> JUKI PLC-1665		KK	Short Gib	7.94		DÜRKOPP-ADLER 169 Mod.for Heavy Thread; 269 Mod.for Heavy Thread			
130.08.791						130.08.795R						130.08.800R		Regulating needle guard			130.08.801R									
		Code Similar Article 130.08.758			SHORT GIB									Code Similar Article 130.08.650		STANDARD EXECUTION								Code Similar Article 130.08.787R		For thread bigger than 1mm diameter; Reg.needle guard STANDARD EXECUTION
	KK	Short Gib	7.92	NBL	<i>91-266 685-91</i> PIFAFF 1422; 1422-720/.. bis 8,0; 1422-900/..; 1422-926/06 b 8; 1426-720/..; 1426-720/04..; 1426-900/..; 1426-926/04; 3819-2/01; 3819-2/03		KK	Short Gib	7.94	NBL	<i>214-35854 Cap System</i> JUKI LS-1342-7		KK	Short Gib	7.94	NBL	<i>0169 001814 mod.for TR.</i> DÜRKOPP-ADLER 269 Mod.for Trimming OMAC		KK	Short Gib	8.00 H	NBL	<i>0491 012041</i> DÜRKOPP-ADLER N291; N292			
130.08.805		Under trimming mach.				130.08.816R						130.08.821R		Under trimming mach.; Regulating needle guard			130.13.020									
		Code Similar Article 130.22.516			DROP-IN EXECUTION									Code Similar Article 130.08.662		W/O UNDER TRIMMING MACH.										
	KK	Short Gib	8.00 H	NBL	<i>0294 001601</i> DÜRKOPP-ADLER 294		KK	Short Gib	8.00 H	NBL	<i>0295 001401</i> DÜRKOPP-ADLER 295; 296; B295; B296		KK	Short Gib	8.00 H	NBL	<i>0935 745210</i> DÜRKOPP-ADLER 745		KL	Short Gib	10.0 H	NBL	<i>0467 150094</i> DÜRKOPP-ADLER 467; 767 <i>107-22551</i> JUKI LU-2210; LU-2260 WANPING TW2-B891			
130.13.024						130.13.055						130.13.065					130.13.251									
	KL	Short Gib	10.0 H	NBL	<i>0467 150804</i> DÜRKOPP-ADLER 467; 767		KL	Full Gib	10.0 H	NBL	<i>0467 150104</i> DÜRKOPP-ADLER 467		KL	Short Gib	10.0 H	NBL	<i>0467 150494</i> DÜRKOPP-ADLER 467; 767		KL	Short Gib	10.0 H	NBL	<i>0467 150014</i> DÜRKOPP-ADLER 467; 767 HIGHLEAD GC 20688-1D			
130.13.255		Under trimming mach.				130.13.258		Under trimming mach.				130.13.261		Under trimming mach.			130.13.265									
		Code Similar Article 130.13.289			WITH NEEDLE GUARD																					



	0767 150194 DÜRKOPP-ADLER 767-FA-273; 767-FA-373-RAP-HP; 767-FAS-373-RAP-HP; 767-VF-373	KL	Short Gib	10 H	NBL		07-044A-106L GARUDAN GF-113-447; GF-133-448 SUNSTAR KM-1060BL-7	KK	Short Gib	10.0 H	NBL		24900-28143 KSL KL110	KL	Short Gib	10.0 H	NBL		60482 SEIKO BBW (ALL CLASSES); BBW-8BL; BBW-8BLC; BBW-8BLC-BTFL-CDDS	KL	Short Gib	10.0 H	NBL			
130.13.270	Under trimming mach.					130.13.282	Under trimming mach.					130.13.289	Under trimming mach.					130.13.291	Under trimming mach.							
												Code Similar Article 130.13.289DC10	DC10 COATED													
	0467 150094 with Cap DÜRKOPP-ADLER 467; 767 107-22551 with Cap JUKI LU-2210; LU-2260 SEIKO BBW (ALL CLASSES)	KK	Short Gib	10.0 H	NBL		0467 150014 with Cap DÜRKOPP-ADLER 467; 767 HIGHLEAD GC 20688-1D	KK	Short Gib	10.0 H	NBL		0667 155604 DÜRKOPP-ADLER 867-190020; 867-190322; 867-290020; 867-290322; 867-160020; 867-160122; 888	KL	Short Gib	8.0 H	NBL		0667 155604 Heavy Thread DÜRKOPP-ADLER 867-190020 Mod.for Heavy Thread; 867-290020 Mod.for Heavy Thread; 867-290322 Mod.for Heavy Thread	KL	Short Gib	8.0 H	NBL			
130.13.294	Under trimming mach.					130.13.298	Under trimming mach.					130.13.350	Under trimming mach.					130.13.370	Under trimming mach.;							
Code Similar Article 130.13.251	LACTH SYSTEM,DROP-IN VERSION					Code Similar Article 130.13.265	LACTH SYSTEM,DROP-IN VERSION					Code Similar Article 130.13.370	HEAVY MATERIAL					Code Similar Article 130.13.350	Under trimming mach.;	Bobbin thread control						
	0767 150324 DÜRKOPP-ADLER 767; 767-AE-573; 767-FAS-473; 767-FAS-573; 767-VF-573 HE41J07101 HIGHLEAD Model	KL	Short Gib	10.0 H	NBL		0667 155634 DÜRKOPP-ADLER 867-190040; 867-190040-70; 867-190342-70; 867-290040-70; 867-290342; 867-290342-70	KL	Short Gib	8.0 H	NBL		0767 150324 Heavy Thread DÜRKOPP-ADLER 767 Mod.for Heavy Thread	KL	Full Gib	9.52			B1830-563-OAO JUKI LH-513; LU-1508NS; LU-1509N; LU-1560; LU-563; LU-563N TAKING TK-86							
130.13.500	Under trimming mach.					130.13.550	Under trimming mach.					130.13.571L	With NoiseLess hook patent; Heavy material					130.15.000								
Code Similar Article 130.13.571L	WITH NOISELESS HOOK PATENT,HEAVY THREAD																	Code Similar Article 130.15.000R	REGULATING NEEDLE GUARD							
	B1830-563-BAO JUKI LU-1508NH; LU-563-3 412307 SINGER 211U 867A; 211UX 567 222098000 YAKUMO (NAKAJIMA) 241L; 481L; 482 L	KL	Short Gib	9.52			JC6100-022A GOLDEN WHEEL CS-3100L; CS-871L MN12B0120 MITSUBISHI LT2-2220-BOB 09-029A-740L SUNSTAR KM2-740BL; KM-740BL	KL	Full Gib	9.52			LT2-H620; LT2-H620H UNICORN	KL	Full Gib	9.52			CS-3L-7241; CS3L-7241 GOLDEN WHEEL GC 20618-2; GC 20698-1 MP02B0120 MITSUBISHI DU-105-22; LU2-420-BOB							
130.15.010						130.15.016						130.15.022						130.15.024								
	MN74E0120 MITSUBISHI LT2-230-B1T; LW2-240 NITAKA TC2-B872-40 TYPICAL GC 6220BD	KL	Full Gib	9.52			510008 SINGER 2110X-104; 2110X-106; 211A 566; 211G 566; 211G 566A; 211G 867A; 211GX 114; 211X 104; 211X 106; 212G; 212GX 109; 212GX 2	KL	Full Gib	7.92			150966-901 LT2-B837; LT2-B837-5 15040 CONSEW CONSEW 254 RBH-1; 255 RBL-3 NITAKA TC-28; TC-288B	KL	Full Gib	9.52			153912-901 LT2-B838; LT2-B838-5 15502 CONSEW 333; 339; 339 RBL-3 2121414-310 TOYOTA AD 331 L							
130.15.030	Under trimming mach.					130.15.040						130.15.050						130.15.061								
	14505 CONSEW 389 RB-1; 389 RB-HP-1 HIGHLEAD GC 24608-1L 14505 SEIKO LPWN-28BL; LW-27L	KL	Full Gib	10.0 H			14005 CONSEW 282 RB-1; 288 RB-1; 289 B; 289 RB-1 14005 SEIKO LPW-7L; LPW-8BL; LPW-8L; LPWN -8BL	KL	Short Gib	10.0 H			CSU-4250BT GOLDEN WHEEL HIGHLEAD GC 20698-2-D MP43A0120 MITSUBISHI LU2-4412-B1T; LW2-410	KL	Full Gib	9.52			156514-901 BROTHER LT2-B882							
130.15.064						130.15.075						130.15.085						130.15.090								
												Code Similar Article 130.15.085R	REGULATING NEEDLE GUARD													
	SA1685-002 BROTHER LT2-B872; LT2-B872-3 TYPICAL GC 6872H WANPING TW2-B872	KL	Full Gib	9.52			S09263-901 BROTHER LT2-B872; LT2-B872-5 07-054A-750L SUNSTAR KM-757-BL; KM-757-BL-7 TYPICAL GC 6872H; GC 6872M	KL	Full Gib	9.52			213-34552 JUKI LU-1510-7; LU-1510-70RB; LU-1560-7	KL	Short Gib	9.52			LT2-B837; LT2-B837-5 NITAKA TC-2508; TC-288; TC-8B 15040 SEIKO LLW-8BL; LSW-26BL							
130.15.125	With special hard treatment					130.15.128						130.15.137	Under Trimming Mach.					130.15.155								
Code Similar Article 130.15.128	STANDARD EXECUTION					Code Similar Article 130.15.125	WITH SPECIAL HARD TREATMENT					Code Similar Article 130.15.137R	REGULATING NEEDLE GUARD													



	KL	Full Gib	9.52			KL	Full Gib	9.52			KL	Short Gib	9.52			KL	Short Gib	9.52	NBL	
G173 SIRUBA UF916-X2-; UF916-X2-U; UF926-X2- Under trimming mach.; UF926-X2-U						34104 SEIKO LLW-28BL/CS; LLWH-28BL/CS; LLWH-8BL/CS; LSWN-28B; LSWN-28BL					34041 SEIKO .LW-8BL/CS; LSWH serie; LSWN serie; LSWN-8BL; LSWN-8BLV					213-87055 JUKI LU-1510N-7; LU-1511N-7; LU-1560N-7				
130.15.166						130.15.178					130.15.181					130.15.183				
						Code Similar Article 130.15.181					Code Similar Article 130.15.178					Code Similar Article 130.15.183R				
	KH	Full Gib	10.0 H				KH	Full Gib	9.52			KH	Full Gib	9.52			KH	Full Gib	9.52	
14706 SEIKO LHPW-8BL; LPW-27BLK TYPICAL CS-8370; CS-8372 WANPING TW5-8370; TW5-8372						MN52E0120 w/o Cap MITSUBISHI LU2-410; LU2-410-B1T; LU2-430; LU2-430-B; LU2-430-B1T; LU2-4410-B1T; PLY-7206					MN26B0120 BAOMA GC20538-C MITSUBISHI LT2-2240-BOB TYPICAL GC 20202-1; GC 6220B					155466-901 BROTHER LT2-B836; LT2-B836-3				
130.19.000						130.19.005					130.19.010					130.19.015				
						Code Similar Article 130.19.005R														
	KH	Full Gib	9.52				KH	Short Gib	9.52			KH	Full Gib	9.52			KH	Full Gib	9.52	
B1830-521-OAO w/o Cap JUKI LH-527; LU-1565; LU-1565N; LUH-526						B1830-521-HAO w/o Cap JUKI LU-1565N; LUH-521; LUH-526; LUH-527 B1830-521-HAO- w/o Cap YAKUMO (NAKAJIMA) 242L					GOLDEN WHEEL CS-7175-BT HIGHLEAD GC 20528-B-D MN62E0120 w/o Cap MITSUBISHI PLY-7181; PLY-7202					16407- CONSEW 327 RB-1; 328 RB-1 16407 SEIKO LSW-26BL-R; LSW-7L-G SUNSTAR KM-560				
130.19.020						130.19.025					130.19.030					130.19.035				
	KH	Short Gib	9.52				KH	Full Gib	9.52			KH	Full Gib	9.52			KH	Full Gib	9.52	
15850- CONSEW 327 RB-1; 328 RB-1 15850 SEIKO LSW-27BLK; LSW-28BLK SUNSTAR KM-560						SA1692-002 w/o Cap BROTHER BAS-612; LT2-B875-3; TN-875A-005 G166 SIRUBA T828-75-__H; T828-75-__M					SA1689-102 w/o Cap BROTHER BAS-610; BAS-611 GEMSY 872-7; 875-7 TYPICAL GC 6875HD3					SA1692-102 w/o Cap BROTHER BAS-613; LT2-B875 228-14255 w/o Cap JUKI LH-3178; LH-3188 TYPICAL GC 6875H				
130.19.040						130.19.042					130.19.045					130.19.050				
						With special hard treatment					Under trimming mach.					Code Similar Article 130.19.042				
						Code Similar Article 130.19.050					Code Similar Article 130.19.051					Code Similar Article 130.19.042				
	KH	Full Gib	9.52				KH	Full Gib	9.52			KL	Short Gib	7.94	NBL		KL	Short Gib	7.94	NBL
SA1689-002 w/o Cap BROTHER BAS-610; BAS-6150 GEMSY 872-7; 875-7 G168 SIRUBA T828-75-M-U						228-19452 w/o Cap JUKI LH-3178-7; LH-3182-4					0268 151814 DÜRKOPP-ADLER 167; 168; 267; 268					0268 151834 DÜRKOPP-ADLER 268FA; 268-FAP-273-1; 268-FAP-73-1				
130.19.051						130.19.052					130.22.000					130.22.010				
With special hard treatment; Under trimming mach.						Under trimming mach.					Code Similar Article 130.22.042R					Code Similar Article 130.22.043R				
Code Similar Article 130.19.045											Code Similar Article 130.22.042R					Code Similar Article 130.22.043R				
	KL	Full Gib	7.94	NBL			KL	Short Gib	7.94	NBL		KL	Full Gib	7.94	NBL		KL	Short Gib	7.94	NBL
214-41753 JUKI LS-1342-7						214-35854 JUKI LS-1342-7					214-31457 JUKI LS-1342					214-35458 JUKI LS-1342				
130.22.028						130.22.034					130.22.035					130.22.039				
Under Trimming Mach.						Under Trimming Mach.										Under trimming mach.				
Code Similar Article 130.22.028R						Code Similar Article 130.22.034R					Code Similar Article 130.22.035R					Code Similar Article 130.22.039R				
	KL	Short Gib	7.94	NBL			KL	Short Gib	7.94	NBL		KL	Short Gib	7.94	NBL		KL	Short Gib	7.94	NBL
B1830-311-OAO JUKI LS-311 MITSUBISHI LU3-6860 B1830-311-OAO- YAKUMO (NAKAJIMA) 341						0268 150734 DÜRKOPP-ADLER 167; 168; 267; 268 JUKI PLC-1660L; PLC-1760L					0268 150724 DÜRKOPP-ADLER 268FA; 268-FAP-273-1; 268-FAP-73-1 400-38731 R JUKI PLC-1660-7; PLC-1710-7; PLC-1760-7					0169.001814 R Drop-in ver DÜRKOPP-ADLER 169; 269				
130.22.040						130.22.042R					130.22.043R					130.22.044R				
						Regulating needle guard					Regulating needle guard; Under trimming mach.					Regulating needle guard				
						Code Similar Article 130.22.000					Code Similar Article 130.22.010					Code Similar Article 130.08.662				





KL	Short Gib	7.94	NBL	KL	Short Gib	7.94	NBL	KL	Short Gib	7.94	NBL	KL	Full Gib	7.92	NBL	
	<u>26010197</u> IVOMAQ MITT 4400-204RT; MITT 4400-204RTCA; MITT 4400-4RTA1; MITT 4400-4RTCA				<u>230-58555 R</u> JUKI PLC-1760				<u>0268-151814 R Extra heav</u> DÜRKOPP-ADLER 268 Mod.for Heavy Thread <u>26010002 R Drop-in ver.</u> IVOMAQ CI 3000; MITT 4400 <u>230-28053 R Heavy duty</u> JUKI PLC-1660L; PLC-1665				<u>91-176 440-91</u> PFAFF 1445 Drop in; 1445-900/. B			
130.22.049R	Under trimming mach.; Regulating needle guard			130.22.051R	Regulating needle guard			130.22.052R	For thread bigger than 1mm diameter STANDARD EXECUTION			130.22.510				
								Code Similar Article 130.08.795R								
KL	Short Gib	7.92	NBL	KL	Short Gib	7.92	NBL	KL	Short Gib	7.92	NBL	KL	Short Gib	7.92	NBL	
	<u>91-176 442-91</u> PFAFF 1445; 1445-900/.. C; 3587-2/01				<u>91-266 150-91</u> PFAFF 1422; 1422-720/.. bis 8,0; 1422-926/04 b 8; 1426-720/..; 1427-926/04; 1428-926/06..; 1525-900/81 ; 1526-900/81 ; 3819-2/01				<u>91-266 786-91</u> PFAFF 1525-901/01; 3587-1420; 3587-2/01				<u>91-164 920-91</u> PFAFF 1421; 1521			
130.22.515				130.22.516	Under trimming mach. Code Similar Article 130.08.805			130.22.519	Under trimming mach.			130.22.522	Under trimming mach.			





GANCIO ROTATIVO TIPO W & W
W & W TYPE ROTARY HOOK
W & W - UMLAUFGREIFER
CROCHET ROTATIF TYPE W & W
GARFIO ROTATIVO DE TIPO W & W
LANÇADEIRA ROTATIVA TIPO WHEELER & WILSON





KH	Full Gib	7.94	H	KH	Full Gib	7.94	H	KH	Full Gib	7.94	H	KH	Full Gib	7.94	H	
	<u>91-008 250-91 w/o BC</u> PFAFF 110; 114; 116; 3114; 3115				<u>91-120 710-91 w/o BC</u> PFAFF 3116				<u>0098 150074 w/o BC</u> DÜRKOPP-ADLER 254; 255; 264; 91; 98 <u>210533</u> SINGER 107U02; 107W; 107W 1 SUNSTAR DPK-2				<u>S34847-901</u> BROTHER LZ2-B852; LZ2-B853 <u>2130504-301-</u> CONSEW 347R-1A; 347R-2A <u>2130504-310</u> TOYOTA AD 5022; AD 555			
130.12.001				130.12.019				130.12.026				130.12.051	Code Similar Article 130.12.051TTN		TTN COATED	
KH	Full Gib	7.94	H	KH	Full Gib	7.94	H	KH	Full Gib	7.94	H	KH	Full Gib	7.94	H	
	<u>S34847-901 TTN</u> BROTHER LZ2-B852; LZ2-B854 <u>2130504-301-TTN</u> CONSEW 347R-1A; 5457R-43 <u>MT70A0120 TTN</u> mitsubishi LZ-720; LZ-720-11				HUANAN G16-1; G16; G16-1 <u>B1808-761-OAO</u> JUKI LBH-761; LBH-763 SHANGGONG G15				<u>971963-4-00</u> NECCHI 400-100				<u>159156-901</u> BROTHER BAS-500; BAS-810 <u>387702-8-11</u> NECCHI 419-100 <u>BR-159155-001 w/o BC</u> SINGER 471U			
130.12.051TTN	TTN coated Code Similar Article 130.12.051			130.12.068				130.12.082				130.12.084				
KH	Full Gib	7.94	H	KH	Full Gib	7.94	H	KH	Full Gib	7.94	H	KH	Full Gib	7.94	H	
	<u>141307-901</u> BROTHER LH4-B814 <u>387702-8-10</u> NECCHI 418-100				<u>34802</u> PANDA JL-457A SINGER 457G STAGER DZ S310				<u>34802 TTN</u> PANDA JL-457A SINGER 457G STAGER DZ S310				<u>971955-4-00</u> NECCHI 411-100			
130.12.091				130.12.099	Long point Code Similar Article 130.12.099TTN			130.12.099TTN	Long point; TTN coated Code Similar Article 130.12.099			130.12.111				
KH	Full Gib	7.94	H	KH	Full Gib	7.94	H	KH	Full Gib	7.94	H	KH	Full Gib	7.94	H	
	<u>1930 12 00 w/o BC</u> REFREY 1930-51/52; 1930-81/82; 1931				<u>MT50A0120</u> MITSUBISHI LZ-710; LZ-710-11; LZ-760; LZ-760-11				<u>536</u> CONSEW 347R <u>536</u> STAGER DZ-S310; SZ 310-4N; SZ 310-5-11N; SZ 310-5-1N; SZ 310-5-1WN				<u>91-269 245-91 w/o BC</u> PFAFF 3119			
130.12.122				130.12.146				130.12.150				130.12.166				







KH	Full Gib	7.00 H	--	KH	Full Gib	7.94 H	--						
	004078.700.00 w/o BC BERNINA 217; 317; 517; 540 B-814-2 w/o BC REFREY 417; 427VZ; 428; 430 772814 w/o BC SINGER 807; 827				B-814-1-930N w/o BC REFREY 930; 931								
130.12.501				130.12.512									
Code Similar Article 130.12.500	COMPLETE KK HOOK WITH BC			Code Similar Article 130.12.511	COMPLETE KK HOOK WITH BC								





CAPSULA BC
CB BOBBIN CASE
SPULENKAPSEL FÜR CB GREIFER
BOITE A CANETTE POUR CROCHET BC
CAPSULA PARA GARFIO BC
CAIXA DE BOBINA PARA LANÇADEIRA BC

KP		--		KP		--		KP		--		KP		--	
	6017 15277 CONSEW 118 SINGER 15-30; 16				15277/B SINGER 15-30; 16; 69				91-006 843-91 PFAFF 34 A; 34 B; 34 C				20176-4-05 NECCHI 603; IA; NORA		
115.00.019				115.00.050				115.00.087				115.00.099			

KP		--		KP		NBL		KP		MF		KP		MF	
	1505-4-00 62740 NECCHI 420; 421; 422 SINGER 31-15; 431D 200A; 431D 201A; 431T 200A				23502 SINGER 71; 71-101				0570 001243/A DURKOPP-ADLER 570				91-130 590-91 PFAFF 3125 A; 3125 B; 3337 A; 3337 B; 3339 A; 3339 B; 3370 A; 3370 B		
115.00.111				115.00.187				115.00.218				115.00.229			

KP		--		KP		MF		KP		--		KP		--	
	43725 SINGER 269W				91-024 423-91 PFAFF 3125 C; 3136; 3331; 3336 C; 3337 C; 3339 C; 3370 C				GARUDAN GS-1828; GS-1836 B1828-980-OAO JUKI LK-1850; LK-284; LK-980 418047 SINGER 469U 111H; 469U 139H				B1828-980-OAB JUKI AMS-210A; AMS-212A		
115.00.248				115.00.262				115.00.277				115.00.286			

CAPSULA PER GANCIO ROTATIVO
BOBBIN CASE FOR ROTARY HOOK
SPULENKAPSEL FÜR UMLAUFGREIFER
BOITE A CANETTE POUR CROCHET ROTATIF
CAJA DE BOBINAS PARA GARFIO ROTATIVO
CAIXA DE BOBINA PARA LANÇADEIRA ROTATIVA

KP		--		KP		--		KP		--		KP		--	
	100369-001 BROTHER DB2-B767; DB2-B767-5 CONSEW 105; 210B; 315 R MF10E0125 MITSUBISHI LS2-150-MOB				84020 0266 ALTIN 8332; 8334 GLOBAL ZZ-564; ZZ-565 149063 SINGER 191D 200 AA				275091 SINGER 402W				971861-4-00 NECCHI 527; 720; 721; 750; 752; 840; RZI 173058 SINGER 306M; 319; 320		
130.06.019				130.06.036				130.06.046				130.06.056			
Code Similar Article 130.06.298	NBL														

CM Cerliani special coating for HEAVY DUTY

The research made by **CM Cerliani** through the Years, has involved countless suppliers, specialists, several Italian and foreign Universities and a strict cooperation with the most important sewing machines manufacturers Worldwide.

Among the best-achieved results only those few have been selected for the commercialization, which presented the best price/performance ratio.

Further **CM Cerliani** has chosen to back diversified solutions on the basis of the different market segment requirements.

The special coating presented in the following data sheet, has been specially developed for very heavy sewing:

DC 10	
glossy black coating on the hook body, gib and basket	
PROPERTIES	
PERFORMANCES	
LUBRICATION	
APPLICATION FIELDS	
PROPERTIES	
<ul style="list-style-type: none"> - extreme high hardness (3000 HV) - very thin coating thickness (3 µm) - uniform structure 	
<ul style="list-style-type: none"> - dry sewing up to 4000 stitches per minute - low friction coefficient - extremely high wear-resistance of the whole hook through coating both race and hook point - very long service life (effect is even more evident when abrasive threads are used) - proven reliability 	
<ul style="list-style-type: none"> - not necessary within the indicated conditions. If present, it can enhance the performances of endurance and smoothness 	
<ul style="list-style-type: none"> - <u>very heavy sewing</u> and in the presence of very abrasive threads - where there are problems of great wear also on the point of the hook - where dry sewing at high speed is required 	

CM Cerliani: the hook technology lives here!

CM Cerliani special coating for EMBROIDERY

Since years **CM Cerliani** is engaged in constant research for new material and coatings that permit to improve further the performances of the hook.

The research made by **CM Cerliani** through the Years, has involved countless suppliers, specialists, several Italian and foreign Universities and a strict cooperation with the most important embroidery machines manufacturers Worldwide.

Among the best-achieved results only those few have been selected for the commercialization, which presented the best price/performance ratio.























Further **CM Cerliani** has chosen to back diversified solutions on the basis of the different market segment requirements.

The special coating presented in the following data sheet, has been specially developed for the embroidery field:













<h2 style="margin: 0;">DC 20</h2> <p style="margin: 0; font-weight: normal;">glossy black coating on the basket</p>	
PROPERTIES	
PERFORMANCES	
LUBRICATION	
APPLICATION FIELDS	
PROPERTIES	
PERFORMANCES	
LUBRICATION	
APPLICATION FIELDS	

CM Cerliani: the hook technology lives here!

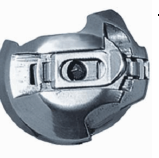
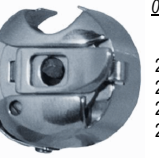









 105032 SINGER 306	 112 327 ALFA 201-209; 214-217 554577-4-00 NECCHI 860	 61413E UNION SPECIAL 61200; 61300; 61400; 61900; 63400; 63900	 0396 150784 DÜRKOPP-ADLER 296; 396
130.06.065	130.06.069	130.06.071	130.06.084
	Code Similar Article 130.06.128 MF	Code Similar Article 130.06.304 NBL	Code Similar Article 130.06.164 MF
 17034 NO NBL CONSEW 277 R-2; 277 RFS 0069 005784 DÜRKOPP-ADLER 69 91-009 076-61 NO NBL PFAFF 134-0-K-6	 523404 IDEAL 6855 971878-4-00 NECCHI 800; 895-101; 895-260; 895-264; 895-570; RVM; SM; UAN-1531	 0211 001115 NO NBL ANKER-PHOENIX 29; 39 DÜRKOPP-ADLER 213; 215; 218; 265-101; 265-15135; 265-18103; 289; 489	 D1837-555-BAA MF JUKI DDL-555; DLN 415-5 MF40E0125 MF MITSUBISHI LS2-1280-M1T 52237 MF SINGER 191D; 591C; 591U; 771G
130.06.106	130.06.108	130.06.110	130.06.125
Code Similar Article 130.06.320 NBL	Code Similar Article 130.06.159 MF	Code Similar Article 130.06.166 MF	Code Similar Article 130.06.298 NBL
 91 12 60 REFREY 920; 920/3; 921; 921/3; 925; 925/3; 927/3	 72-113-101 GLOBAL ZZ-564; ZZ-565 MINERVA 72-113-101; 72-113-102 143390 MF SINGER 191D 200 AA	 222528-4-00 NECCHI 891-570; 891-571; 895-256; 895-260; 895-261; 895-263; 895-570; 895-571; UAN-2641; UAN-2661; UAN-2681; UAN-2682	 0396 150824 DÜRKOPP-ADLER 550-16-2; 550-16-3; 550-16-5; 550-16-6 OMAC EOS
130.06.128	130.06.135	130.06.159	130.06.164
Code Similar Article 130.06.069 W/O NBL	Code Similar Article 130.06.300 NBL	Code Similar Article 130.06.108 W/O NBL	Code Similar Article 130.06.084 W/O NBL
 0211 001115 MF DÜRKOPP-ADLER 211; 212; 213; 214; 215; 218; 265-101; 265-15135; 265-18103; 265-203; 265-25407	 91-009 076-61 MF PFAFF 487-900/..; 560 RESTA H228; H304 SEIKO HC-2B; LSC-8B	 61413E MF UNION SPECIAL 61200; 63400; 63900	 527; 720; 721; 840 NECCHI
130.06.166	130.06.172	130.06.178	130.06.203
Code Similar Article 130.06.110 W/O NBL	Code Similar Article 130.06.320 NBL	Code Similar Article 130.06.304 NBL	With thread passage guide
 410025 NO NBL SINGER 20U-13; 20U-23; 20U-31; 20U-34	 0271 000771 MF DÜRKOPP-ADLER 271; 272	 410025 MELCO AMAYA SINGER 20U-13; 20U-23; 20U-31; 20U-34	 KF220440 NBL BARUDAN BEDSH serie MELCO AMAYA ME0503000 NBL TAJIMA TME; TMEX; TMLG
130.06.209	130.06.229	130.06.233	130.06.240
With thread passage guide		With thread passage guide	With thread passage guide
Code Similar Article 130.06.233 NBL		Code Similar Article 130.06.209 W/O NBL	Code Similar Article 130.06.348 W/O NBL
 218 210 ALFA 112; 119; 3842; 3847; 3940	 225912-4-00 NECCHI UAN-800	 574.100 ZSK 166M; 167; 167E; 168; 168E; 169E; 170-174; 170E; 171E; 172; 174; Serie J; Serie L; Serie M; Serie T; Serie X; Serie XB; Serie XL	 91-009 076-61 14mm GOLDEN WHEEL CS-2280 PFAFF 134-0-92; 333-712/02(-900...)
130.06.251	130.06.258	130.06.260	130.06.294
		With thread passage guide	Needle slot 13.5 mm
		Code Similar Article 130.06.397 WITH THREAD PASSAGE EYE	
 148350-101 BROTHER DB2-B767; DB2-B767-5 110-38759 JUKI DDL-555; DLN 415-5 52237 NBL SINGER 591C; 591U; 771G	 72-113-101 GLOBAL ZZ-565-TD MINERVA 72-113-101; 72-113-105	 61413E NBL UNION SPECIAL 61200; 61300; 61400; 61900; 63400; 63900	 17034 CONSEW 277 R; 277 R-2; 277 RB; 277 RFS 91-009 076-61 PFAFF 138; 3588; 3588-02/01; 480; 487; 560; 561; 950
130.06.298	130.06.300	130.06.304	130.06.320
Code Similar Article 130.06.125 MF	Code Similar Article 130.06.135 MF	Code Similar Article 130.06.178 MF	Code Similar Article 130.06.172 MF

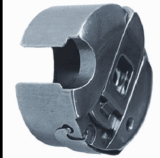

	91-167 597-91 PFAFF 437; 460; 838; 930 AB; 937; 937-900/..; 938-716/.. (-900/..)		63913A UNION SPECIAL 61200; 61900; 63900		147149 SINGER 241; 251; 281		BARUDAN BEAM serie; BEMS serie TAJIMA TFGN; TMLF
130.06.322		130.06.342		130.06.346	With thread passage guide	130.06.348	With thread passage guide
						Code Similar Article 130.06.240	NBL
	52237 Magnet SINGER 241; 251; 281		PFAFF 134-0-92; 138; 230; 260; 331; 333-712/02(-900...)		91-174 955-91 PFAFF 335-G (-900/..); 337-G (-900/..); 3822-1/22 (G)		0271 150144 DÜRKOPP-ADLER 271; 271-140331; 271-140341; 271-140342; 271-140432; 271-140442; 272-140341; 272-140342; 272-640642; 273-140432; 550-16-23; 550-16-26
130.06.351	With magnet	130.06.359		130.06.373		130.06.376	
Code Similar Article 130.06.298	NBL						
	0281 150084 DÜRKOPP-ADLER 281 GEMSY 9000W-7 91-262 377-91 PFAFF 1051; 1053; 1181; 1183		B1837-245-OAO JUKI DSC-244; DSC-244V; DSC-245; DSC-245V 109471005 YAKUMO (NAKAJIMA) 381Y ZOJE ZJ2628		91-106 372-91 PFAFF 1010; 1025; 1037; 1047; 1050; 1069; 1150; 1151; 134; 134-0-K-6		570.568 ZSK 166M; 167; 167E; 168; 168E; 169E; 170-174; 170E; 171E; 172; 174; Serie J; Serie L; Serie M; Serie T; Serie X; Serie XB; Serie XL
130.06.378		130.06.380		130.06.390	Special regulating screw	130.06.397	With thread passage eye
				Code Similar Article 130.06.106	STANDARD SCREW	Code Similar Article 130.06.260	WITH THREAD PASSAGE GUIDE
	95-774 442-91 PFAFF 2438; 2438-916						
130.06.416							

CAPSULA PER GANCIO ROTATIVO GRANDE CAPACITÀ
BOBBIN CASE FOR LARGE CAPACITY ROTARY HOOK
SPULENKAPSEL FÜR GROSSRAUM - UMLAUFGREIFER
BOITE A CANETTE POUR CROCHET ROTATIF GRANDE CAPACITE
CAJA DE BOBINAS PARA GARFIO ROTATIVO DE GRAN CAPACIDAD
CAIXA DE BOBINA DE GRANDE CAPACIDADE PARA LANÇADEIRA ROTATIVA

	147790-001 NO NBL BROTHER BAS-423; BE-0101B-AC B1837-201-OAO JUKI DDL-560; DNU-241HS 522456 SINGER 121C 300		151845-001 MF BROTHER BAS-350; BAS-416 2110804-301 MF CONSEW 120; 205 RB 0009040135 RESTA H220-G3; H220-G3L		137A MF CONSEW 146 RBL; 175 RB 137A MF GOLDEN WHEEL CS-2160; CS-2161 35575 MF MEISTERGRAMM M700XL		CONSEW 176 1650-519 MF SINGER 121D 300; 1650E 1650-519 MF VI.BE.MAC 2650 EV5
130.10.000		130.10.007		130.10.013		130.10.015	
Code Similar Article 130.10.007	MF	Code Similar Article 130.10.045	NBL	Code Similar Article 130.10.050	NBL	Code Similar Article 130.10.048	NBL
	0271 001034 DÜRKOPP-ADLER 271; 8967-160180; 8967-160182		IE 35780 IDEAL 6881 227526-4-00 NECCHI 891-104 SEIKO LAH-1LC		IE 35780PT IDEAL 6881 NECCHI POCKET SETTER SEIKO LCW-8		18045 MF CONSEW 206 RB; 206 RB-5 18045 MF JUKI DNU-261H SEIKO STH-serie
130.10.023		130.10.028	With thread passage eye	130.10.030	With thread passage guide	130.10.037	
		Code Similar Article 130.10.030	WITH THREAD PASSAGE GUIDE	Code Similar Article 130.10.028	WITH THREAD PASSAGE EYE		







	BARUDAN BEAM serie; BESR serie <u>MEC503000DBM</u> TAJIMA TFMX; TFMX-II C		GARUDAN GF-131-446 MH/L <u>G205</u> SIRUBA YC619-X2 <u>151845-001</u> VI.BE.MAC 650 EV		CONSEW 176 <u>239728</u> SINGER 121D 330; 121D 330AA <u>1650-519</u> VI.BE.MAC 650 EV		KSM KSM 220 6 385-24 385 <u>18099</u> SEIKO LZ2-990; SSH-8BLD
130.10.039	With thread passage guide	130.10.045		130.10.048		130.10.050	
Code Similar Article 130.10.056	W/O NBL	Code Similar Article 130.10.007	MF	Code Similar Article 130.10.015	MF	Code Similar Article 130.10.013	MF
	<u>18045 NBL</u> CONSEW 206 RB; 206 RBL-25 <u>B1837-241-HOO</u> JUKI DNU-1541; DSC-246V NITAKA TTC-3750L; YU-380L		GEMSY 7-18A; 8-18A <u>MG44E0125</u> MITSUBISHI DB-189-22BZ; LY2-3310; PLK-1210; PLK-E2010R		BARUDAN BEAT serie; BENT serie TAJIMA TFMX; TFMX-II C		<u>0367 155044</u> DÜRKOPP-ADLER 367-170 010; 367-170 115
130.10.052		130.10.054		130.10.056	With thread passage guide	130.10.059	
				Code Similar Article 130.10.039	NBL		
	KSM KSM 200; KSM 210; KSM 220 ZOJE FB-200		<u>0367 155244</u> DÜRKOPP-ADLER 367; 367-180 010		J.A.M. MODEL FOR JEANS <u>144-36257</u> JUKI LK-1941; LK-1942		<u>S00690-301</u> BROTHER KE-484C; LK3-B484 J.A.M. MODEL FOR JEANS <u>65112</u> MECA TECHNA MultiTech
130.10.061		130.10.067		130.10.500	3 times large capacity BC; With thread passage guide	130.10.510	3 times large capacity BC; With thread passage guide
						Code Similar Article 130.10.515	LIGHT MATERIAL
	<u>S00691-401</u> BROTHER KE-484C; KE-484C-X; LK3-B484 J.A.M. MODEL FOR JEANS		<u>65112/CLB</u> MECA TECHNA MultiTech; TECHNA Unlimitec SOTEXI L2000		<u>91-168 628-91</u> PFAFF 417; 417 (-900/..)B; 419; 419 (-900/..)B; 917 (-900/..)B; 918 (-900/..)B		<u>95-629 679-91</u> PFAFF 3518; 3518 Multidirectional sewing; 418-712; 910
130.10.515	3 times large capacity BC; With thread passage guide	130.10.520	3 times large capacity BC; With Coreless system	130.24.000		130.24.005	
Code Similar Article 130.10.510	STRONG MATERIAL W/O N						
	<u>91-167 084-91</u> PFAFF 3568; 3568-12/11; 3568-2/01; 3568-2/11; 910; 910-Homemaker ver.; 918-Homemaker ver.		<u>642026050</u> BARATTO 158 Serie				
130.24.050		130.30.120					



CAPSULA PER GANCIO ROTATIVO VERTICALE
CAP FOR VERTICAL ROTARY HOOK
SPULENKAPSEL FÜR VERTIKAL - UMLAUFGREIFER
BOITE A CANETTE POUR CROCHET ROOTATIF VERTICAL
CAJA DE BOBINAS PARA GARFIO ROTATIVO VERTICAL
CAIXA DE BOBINA PARA LANÇADEIRA ROTATIVA VERTICAL

	<u>91-010 159-91</u> PFAFF 142 A; 142 B; 343-712/..; 343-G; 344U; 442-720/04; 444 A; 444 B; 448-0 <u>37255-07</u> SEIKO GPB-8W		<u>91-011 498-91</u> PFAFF 142 C; 194-944/01 C; 290; 292 C		<u>91-019 923-91</u> PFAFF 120; 142-721/01 Needles distance from 8mm; 242-720/02 (8,0-30,0)		<u>0068 150804</u> DÜRKOPP-ADLER 67; 68
130.08.014		130.08.070		130.08.315		130.08.342	











 0068 150784 DÜRKOPP-ADLER 67; 68	 971927-4-00 NECCHI 931-100; 931-101; 932-100	 971923-4-00 NECCHI 910-113; 910-158; 910-159; 930-159	 971928-4-00 NECCHI 925-103; 925-403
130.08.344	130.08.368	130.08.392	130.08.395
 971924-4-00 NECCHI 960; 961; 980	 91-113 192-91 GARUDAN GP-410-149 PFAFF 442-R-900/56; 442-R-900/61	 901 12 60/41 REFREY 901/41; 902/41	 10159/1 CIUCANI MC-88; MC-89 IVOMAQ CI 5000
130.08.411	130.08.460	130.08.474	130.08.491
 91-140 650-91 PFAFF 140; 140-900; 141-900/06; 145-900/06; 240; 246-900/..; 290-900	 05 17 0017 ATTILIO FORTE AF 8 CFELCA 26010062 IVOMAQ MITT 4000; MITT 4000-202RDC; MITT 4000-202RTC	 971828-4-10 CONSEW 701 ATC NECCHI 960; 961; 962; 971; 981; 983	 205528-4-10 NECCHI 927-103; 927-203; 927-263; 974; 980
130.08.495	130.08.499	130.08.505	130.08.512
 91-119 458-91 PFAFF 1471 (E)-900/..; 1474-900/..; 1493 (E) -900/.. B/C; 471-900 /.. A; 471-900 /.. B; 491-900/.. A; 491-900/.. B	 91-118 414-91 PFAFF 440-900; 440-900 Leder; 441-0-900; 442-R-900/71; 444-0-900/..; 457-0-900/..	 91-263 392-91 GOLDEN WHEEL CS-8360; CS-8820H NITAKA TC-8361; TC-8855 G401A SIRUBA R718-01H; R728-xxH	 91-263 392-91 PFAFF 571 A; 571 B; 571 C; 574-725/04 A; 574-725/04 B; 574-725/04 C; 594 B; 594 C; 594-725/04 C
130.08.522	130.08.544	130.08.926	130.08.944
 0249 000369 PFAFF 421; 421-900/61-B; 421-900/61-C; 421-900/61-G; 422; 422-720/..; 422-900/..	 0697 004343 MILLION SPECIAL MS-474-510; MS-474-530; MS-491-810; MS-491-830; MS-674-530; MS-674-530P; MS-691-810; MS-691-830; MS-691-830P	 0381 150254 DÜRKOPP-ADLER 238; 241; 249; 541; 548; 697	 0238 006799 DÜRKOPP-ADLER 238-line 13000; 239-line 13000; 249-13315; 249-line 13000; 372-13303; 376-line 15000; 697-6155
130.08.957	Under Trimming Mach.	130.13.129	130.13.140
 0380 000508 DÜRKOPP-ADLER 372; 376-line 15000; 380-line 15305	 0697 004343 DÜRKOPP-ADLER 697-15155; 697-24155	 0381 150254 DÜRKOPP-ADLER 381-160161; 382-160162	 151041-001 BROTHER LT2-B835-3; LT2-B835-5 B1837-528-OAO JUKI LH-528 MN27A0125 MITSUBISHI LT2-2240-MOB For corner stitch
130.13.143	130.13.168	130.13.180	130.17.000
 101-10252 JUKI LH-1150; LH-1152-5; LH-1152-7	 MN50A0125 GOLDEN WHEEL CS-7165-BT MITSUBISHI LT2-2250-M1TW; LT2-250-M	 241676 SEIKO SPW-26 SINGER 138G 102; 236G 130; 236G 131; 236G 132	 S07741-001 BROTHER LT2-B845 G409 SIRUBA T828-45-__X WANPING TW2-B845-5
130.17.010	130.17.015	130.17.020	130.17.025
	For basting stitch		











 <p><u>S07742-001</u> BROTHER LT2-B848; LT2-B848-401 G410 SIRUBA T828-45-X-U <u>07-065A-7907</u> SUNSTAR KM-790-7</p>	 <p><u>S07740-001</u> BROTHER LT2-B842; LT2-B842-905 <u>226-12659</u> JUKI LH-3128 TYPICAL GC 6842HD4</p>	 <p>JACK (FEIQIU) JK 5845-3 <u>226-88154</u> JUKI LH-3168 SUNSTAR KM-790</p>			
130.17.030	130.17.035	130.17.040			





CAPSULA PER GANCIO ROTATIVO VERTICALE GRANDE CAPACITÀ
CAP FOR LARGE CAPACITY VERTICAL ROTARY HOOK
SPULENKAPSEL FÜR GROSSRAUM VERTIKAL - UMLAUFGREIFER
BOITE A CANETTE POUR CROCHET ROTATIF VERTICAL
CAJA DE BOBINAS PARA GARFIO ROTATIVO VERTICAL DE GRAN CAPACIDAD
CAIXA DE BOBINA DE GRANDE CAPACIDADE PARA LANÇADEIRA ROTATIVA

 <p><u>91-018 348-91</u> PFAFF 1240; 541 C; 541 D <u>1901 12 60</u> REFREY 1901; 1902 TYPICAL TW1-1245</p>	 <p><u>971723-4-00</u> NECCHI 910-114; 955-110; 975-460; 975-560; 976; 977-260; 977-261; 977-464</p>	 <p><u>971839-4-00</u> NECCHI 928; 928-101; 928-201; 928-261; 979</p>	 <p><u>0167 001784</u> DÜRKOOP-ADLER 167; 168; 467; 767 <u>26010036</u> IVOMAQ CI 3000 PEMA 286</p>		
130.08.109	130.08.135	130.08.183	130.08.246		

 <p><u>1901 12 60/41</u> REFREY 1901/41; 1902/41</p>	 <p><u>91-018 959-91</u> PFAFF 1246-720/.. (8-30,0); 544-720/02 (8,5-15,2)</p>	 <p><u>0167 150194</u> DÜRKOOP-ADLER 167FA; 267FA</p>	 <p><u>0167 150284</u> DÜRKOOP-ADLER 267LS-263NH1 <u>230-29069</u> JUKI PLC-1665</p>		
130.08.267	130.08.284	130.08.646	130.08.651		

 <p><u>0268 150444</u> DÜRKOOP-ADLER 268FA; 269 Mod.for Trimming <u>230-25257</u> JUKI PLC-1610-7</p>	 <p><u>91-140 287-91</u> PFAFF 1240; 3826-2/01; 540; 541-900/11; 541-900/16 B/C</p>	 <p>ATTILIO FORTE AF 8 CF; AF 8 EL; AF 8 LG</p>	 <p>GARUDAN GP-410-446 <u>91-018 676-91</u> PFAFF 1296-237/06-900/..; 594-900/56-900/01</p>		
130.08.659	130.08.674	130.08.686	130.08.701		

 <p>GOLDEN WHEEL CS-8233 <u>214-31606</u> JUKI LS-1342; LS-321 WANPING TW3-341</p>	 <p><u>91-266 683-91</u> PFAFF 1422; 1422-720/.. bis 8,0; 1426-720/..; 1426-900/..; 1426-926/04; 3819-2/01</p>	 <p><u>0167 001784 Trimming</u> DÜRKOOP-ADLER 467; 767 JUKI LU-2210; LU-2260 SEIKO BBW (ALL CLASSES)</p>	 <p><u>0294 001605</u> DÜRKOOP-ADLER 294</p>		
130.08.766	130.08.814	130.08.824	130.13.047		
		Code Similar Article 130.08.246	STANDARD EXECUTION		

 <p><u>0295 001426</u> DÜRKOOP-ADLER 295; 296; N292</p>	 <p><u>0935 100791</u> DÜRKOOP-ADLER 745</p>	 <p>GARUDAN GF-133-448 <u>07-044A-106C</u> SUNSTAR KM-1060BL-7</p>	 <p><u>MN26A0125</u> MITSUBISHI DN-275-20; LT2-2240-B SHANGGONG GD8-4; GD8-7 <u>B1837-526-OAQ-</u> YAKUMO (NAKAJIMA) 242L</p>		
130.13.060	130.13.069	130.13.287	130.20.000		



 155476-001 BROTHER LT2-B836; LT2-B836-3 130.20.010	 GOLDEN WHEEL CS-7175-BT MN62A0125 MITSUBISHI LT2-250-A/B; LT2-250-A1T; LT2-250-B1T 130.20.015	 CONSEW 327 RB-1; 328 RB-1 16407-9C SEIKO LSW-27BLK SUNSTAR KM-560 130.20.020	 MN52E0125 MITSUBISHI LU2-410; LU2-4410-B1T SIRUBA UF916-X2L_ 130.20.025
 S09278-001 BROTHER LT2-B872 G411 SIRUBA T828-72-M-U 130.20.030	 S09279-001 BROTHER BAS-612 G407 SIRUBA T828-75-__H TYPICAL GC 6875H 130.20.035	 S09280-001 BROTHER BAS-610; LT2-B875 G408 SIRUBA T828-75-H-U ZOJE 875-D3 130.20.040	 102-31553 JUKI LH-1182; LH-1182-5 130.20.045
 228-27257 JUKI LH-3178; LH-3178-7; LH-3182-4; LH-3188; LH-3188-7 130.20.050	 228-19650 JUKI LH-3178; LH-3178-7; LH-3188; LH-3188-7 130.20.055		

CAPSULA PER GANCIO ROTATIVO TIPO W & W
BOBBIN CASE FOR W & W TYPE ROTARY HOOK
SPULENKAPSEL FÜR WHEELER & WILSON - UMLAUFGREIFER
BOITE A CANETTE POUR CROCHET ROTATIF TYPE WHEELER & WILSON
CAJA DE BOBINAS PARA GARFIO ROTATIVO DE TIPO W & W
CAIXA DE BOBINA PARA LANÇADEIRA ROTATIVA TIPO WHEELER & WILSON

 971964-4-00 NO NBL NECCHI 400-100 91-008 243-91 NO NBL PFÄFF 110; 114; 116; 3115 130.14.000 Code Similar Article 130.14.007	 971964-4-00 NBL NECCHI 411-100 130.14.007 Code Similar Article 130.14.000	 0235 000368 NO NBL DÜRKOPP-ADLER 252; 253; 254; 255; 264 B1810-761-OAO JUKI LBH-762; LBH-763 224441 NO NBL SINGER 107U02; 107W 1 130.14.010 Code Similar Article 130.14.015	 107097-101 BROTHER LH4-B814 0235 000368 NBL DÜRKOPP-ADLER 252; 253; 255; 264 224441 NBL SINGER 107G; 107W 1 130.14.015 Code Similar Article 130.14.010
 158471-001 BROTHER LZ2-B852; LZ2-B854 MT70E0125 NO NBL MITSUBISHI LZ-720; LZ-790 502530 NO NBL SINGER 457G 130.14.017 Code Similar Article 130.14.021	 158471-000 BROTHER LZ2-B852 CONSEW 457G MT70E0125 NBL MITSUBISHI LZ-780-11 130.14.021 Code Similar Article 130.14.017	 91-269 243-91 PFÄFF 3119 130.14.027	 004077-70.00 BERNINA 217; 317; 517; 540 B-815-1 REFREY 417; 427VZ; 428; 430 772815 SINGER 807; 827 130.14.500



Cross Reference List by Original Number

Original Number	Original Number of	CM CERLIANI Article Number	Line	NBL Type
0005 002904	DÜRKOPP-ADLER	112.00.025	KK	
0009010029	RESTA	130.06.056	KP	--
0009010050	RESTA	130.01.111	KH	
0009040135	RESTA	130.10.007	KP	MF
0009300029	RESTA	130.06.106	KP	--
0009300029 MF	RESTA	130.06.172	KP	MF
0009300029 NBL	RESTA	130.06.320	KP	NBL
001917-01	MELCO	130.01.399	KH	
001917-01TS	MELCO	130.01.399TS	KH	
002611-01	MELCO	130.09.150	KH	
0037 001514 w/o BC	DÜRKOPP-ADLER	115.00.110	KH	
0037 001614	DÜRKOPP-ADLER	115.00.111	KP	--
004 076 70 00	BERNINA	130.12.501	KH	--
004 076 71 00	BERNINA	130.12.501	KH	--
004 077 70 00	BERNINA	130.14.500	KP	--
004 078 70 00 w/o BC	BERNINA	130.12.501	KH	--
0040.76.70.00	BERNINA	130.12.501	KH	--
0040.76.71.00	BERNINA	130.12.501	KH	--
004076.70.00	BERNINA	130.12.501	KH	--
004076.71.00	BERNINA	130.12.501	KH	--
004077.70.00	BERNINA	130.14.500	KP	--
004078.700.00 w/o BC	BERNINA	130.12.501	KH	--
005 00 290 4	DÜRKOPP-ADLER	112.00.025	KK	
0065 001854	DÜRKOPP-ADLER	112.00.025	KK	
0068 150784	DÜRKOPP-ADLER	130.08.344	KP	
0068 150804	DÜRKOPP-ADLER	130.08.342	KP	
0068 150814	DÜRKOPP-ADLER	130.08.343	KK	--
0068 150824	DÜRKOPP-ADLER	130.08.341	KK	--
0069 005784	DÜRKOPP-ADLER	130.06.106	KP	--
0069 005814 w/o BC	DÜRKOPP-ADLER	130.03.040	KH	
0069 150274 w/o BC	DÜRKOPP-ADLER	130.03.040	KH	
0069 150284	DÜRKOPP-ADLER	130.06.172	KP	MF
0069 150284 NBL	DÜRKOPP-ADLER	130.06.320	KP	NBL
008250 w/o BC	PFAFF	130.12.001	KH	
0089 001784	DÜRKOPP-ADLER	130.06.110	KP	--
009072	PFAFF	130.03.014	KH	
009268	PFAFF	130.03.014	KH	
0096 152814	DÜRKOPP-ADLER	130.01.000	KH	
0096 152814 w/o BC	DÜRKOPP-ADLER	130.01.025	KH	
0097 001784	DÜRKOPP-ADLER	130.06.019	KP	--
0097 001784 Magnet	DÜRKOPP-ADLER	130.06.351	KP	Magnet
0097 001784 MF	DÜRKOPP-ADLER	130.06.125	KP	MF
0098 150054	DÜRKOPP-ADLER	130.14.015	KP	NBL
0098 150074 w/o BC	DÜRKOPP-ADLER	130.12.026	KH	
0099 001814 w/o BC	DÜRKOPP-ADLER	130.01.039	KH	
014415	PFAFF	130.08.965	KK	NBL
0167 001784	DÜRKOPP-ADLER	130.08.246	KP	--
0167 001784 Trimming	DÜRKOPP-ADLER	130.08.824	KP	--
0167 001814	DÜRKOPP-ADLER	130.08.240	KK	--
0167 001814 Reg. needle guard	DÜRKOPP-ADLER	130.08.751R	KK	
0167 001814Reg.needle guard,drop-in ver.	DÜRKOPP-ADLER	130.22.042R	KL	NBL
0167 150084	DÜRKOPP-ADLER	130.08.638	KK	--
0167 150194	DÜRKOPP-ADLER	130.08.646	KP	NBL
0167 150204	DÜRKOPP-ADLER	130.08.642	KK	NBL
0167 150214	DÜRKOPP-ADLER	130.08.648	KK	NBL
0167 150284	DÜRKOPP-ADLER	130.08.651	KP	
0167 150304	DÜRKOPP-ADLER	130.08.650	KK	
0167 150304 Reg.needle guard	DÜRKOPP-ADLER	130.08.800R	KK	

Original Number	Original Number of	CM CERLIANI Article Number	Line	NBL Type
0169 001814	DÜRKOPP-ADLER	130.08.662	KK	--
0169 001814 mod.for TR.	DÜRKOPP-ADLER	130.08.821R	KK	
0169 001814 R Drop-in ver.	DÜRKOPP-ADLER	130.22.044R	KL	NBL
0169 001814 Reg. needle guard	DÜRKOPP-ADLER	130.08.787R	KK	
0199 152814 w/o BC	DÜRKOPP-ADLER	130.01.039	KH	
0204 000335 Magnet	DÜRKOPP-ADLER	130.06.351	KP	Magnet
0211 000275	DÜRKOPP-ADLER	130.06.128	KP	MF
0211 000275 NO NBL	DÜRKOPP-ADLER	130.06.069	KP	--
0211 001101 w/o BC	DÜRKOPP-ADLER	130.05.083	KH	
0211 001102 with Basket	DÜRKOPP-ADLER	130.05.083	KH	
0211 001115	DÜRKOPP-ADLER	130.06.166	KP	MF
0211 001115 NO NBL	DÜRKOPP-ADLER	130.06.110	KP	--
0212 052084 w/o BC	DÜRKOPP-ADLER	130.05.247	KH	
0212 052085	DÜRKOPP-ADLER	130.05.247	KH	
0216 001491 w/o BC	DÜRKOPP-ADLER	130.05.089	KH	
0235 000368 NBL	DÜRKOPP-ADLER	130.14.015	KP	NBL
0235 000368 NO NBL	DÜRKOPP-ADLER	130.14.010	KP	--
0238 006781	DÜRKOPP-ADLER	130.13.134	KK	NBL
0238 006799	DÜRKOPP-ADLER	130.13.140	KP	
0244 001021	DÜRKOPP-ADLER	130.13.020	KK	NBL
0246 003031	DÜRKOPP-ADLER	130.13.065	KK	NBL
0249 000369	DÜRKOPP-ADLER	130.13.129	KP	
0249 000592 K	DÜRKOPP-ADLER	130.13.100	KL	
0249 000616 K	DÜRKOPP-ADLER	130.13.115	KL	
0249 000861	DÜRKOPP-ADLER	130.13.122	KK	--
0252 000781	DÜRKOPP-ADLER	130.12.026	KH	
0265 012321 w/o BC	DÜRKOPP-ADLER	130.05.332	KH	
0265 012322	DÜRKOPP-ADLER	130.05.332	KH	
0265 012786 w/o BC	DÜRKOPP-ADLER	130.05.222	KH	
0265 012787	DÜRKOPP-ADLER	130.05.222	KH	
0267 151814	DÜRKOPP-ADLER	130.08.240	KK	--
0267 151814 Reg. needle guard	DÜRKOPP-ADLER	130.08.751R	KK	
0267 151814Reg.needle guard,drop-in ver.	DÜRKOPP-ADLER	130.22.042R	KL	NBL
0267 151824	DÜRKOPP-ADLER	130.08.751R	KK	
0267 151834	DÜRKOPP-ADLER	130.08.800R	KK	
0268 150174	DÜRKOPP-ADLER	130.08.658	KK	NBL
0268 150174 Reg. needle guard	DÜRKOPP-ADLER	130.08.785R	KK	
0268 150174Reg.needle guard,drop-in ver.	DÜRKOPP-ADLER	130.22.043R	KL	NBL
0268 150184	DÜRKOPP-ADLER	130.08.661	KK	NBL
0268 150444	DÜRKOPP-ADLER	130.08.659	KP	NBL
0268 150724	DÜRKOPP-ADLER	130.22.043R	KL	NBL
0268 150734	DÜRKOPP-ADLER	130.22.042R	KL	NBL
0268 150744	DÜRKOPP-ADLER	130.08.785R	KK	
0268 151814	DÜRKOPP-ADLER	130.22.000	KL	NBL
0268 151814 R Extra heavy duty Drop-in	DÜRKOPP-ADLER	130.22.052R	KL	NBL
0268 151814 Reg. needle guard	DÜRKOPP-ADLER	130.22.042R	KL	NBL
0268 151834	DÜRKOPP-ADLER	130.22.010	KL	NBL
0268 151834 Reg. needle guard	DÜRKOPP-ADLER	130.22.043R	KL	NBL
0268 151854	DÜRKOPP-ADLER	130.08.658	KK	NBL
0268 151854 Reg. needle guard	DÜRKOPP-ADLER	130.08.785R	KK	
0268 151854Reg.needle guard,drop-in ver.	DÜRKOPP-ADLER	130.22.043R	KL	NBL



Original Number	Original Number of	CM CERLIANI Article Number	Line	NBL Type
0268 151864	DÜRKOPP-ADLER	130.08.661	KK	NBL
0269 150054	DÜRKOPP-ADLER	130.08.787R	KK	
0269 150054 mod.for TR.	DÜRKOPP-ADLER	130.08.821R	KK	
0269 150054 mod.for trimming	DÜRKOPP-ADLER	130.08.821R	KK	
0269 151814	DÜRKOPP-ADLER	130.08.662	KK	--
0269 151814 mod.for trimming Reg.needle	DÜRKOPP-ADLER	130.08.821R	KK	
0269 151814 R Drop-in ver.	DÜRKOPP-ADLER	130.22.044R	KL	NBL
0269 151814 Reg. needle guard	DÜRKOPP-ADLER	130.08.787R	KK	
0271 000751 w/o BC	DÜRKOPP-ADLER	130.05.311	KH	
0271 000753	DÜRKOPP-ADLER	130.05.311	KH	
0271 000771	DÜRKOPP-ADLER	130.06.229	KP	MF
0271 001021 w/o BC	DÜRKOPP-ADLER	130.09.050	KH	
0271 001023	DÜRKOPP-ADLER	130.09.050	KH	
0271 001034	DÜRKOPP-ADLER	130.10.023	KP	MF
0271 150034 w/o BC	DÜRKOPP-ADLER	130.05.494DC20	KH	
0271 150124 DC20 w/o BC	DÜRKOPP-ADLER	130.05.494DC20	KH	
0271 150124 w/o BC	DÜRKOPP-ADLER	130.05.494	KH	
0271 150144	DÜRKOPP-ADLER	130.06.376	KP	MF
0272 001121 w/o BC	DÜRKOPP-ADLER	130.05.320	KH	
0272 001123	DÜRKOPP-ADLER	130.05.320	KH	
0281 150084	DÜRKOPP-ADLER	130.06.378	KP	NBL
0281 150103	DÜRKOPP-ADLER	130.05.534	KH	
0281 150104 w/o BC	DÜRKOPP-ADLER	130.05.534	KH	
0291 020931	DÜRKOPP-ADLER	130.13.020	KK	NBL
0294 001401	DÜRKOPP-ADLER	130.13.024	KK	NBL
0294 001431	DÜRKOPP-ADLER	130.13.024	KK	NBL
0294 001601	DÜRKOPP-ADLER	130.13.024	KK	NBL
0294 001605	DÜRKOPP-ADLER	130.13.047	KP	NBL
0294 001611	DÜRKOPP-ADLER	130.13.024	KK	NBL
0295 001401	DÜRKOPP-ADLER	130.13.055	KK	NBL
0295 001426	DÜRKOPP-ADLER	130.13.060	KP	NBL
0295 001481	DÜRKOPP-ADLER	130.13.055	KK	NBL
0367 155014 w/o BC	DÜRKOPP-ADLER	130.09.158	KH	
0367 155044	DÜRKOPP-ADLER	130.10.059	KP	NBL
0367 155214 w/o BC	DÜRKOPP-ADLER	130.09.196	KH	
0367 155244	DÜRKOPP-ADLER	130.10.067	KP	NBL
0367 156014 w/o BC	DÜRKOPP-ADLER	130.09.158	KH	
0367 156044	DÜRKOPP-ADLER	130.10.059	KP	NBL
037 00 151 4 w/o BC	DÜRKOPP-ADLER	115.00.110	KH	
037 00 161 4	DÜRKOPP-ADLER	115.00.111	KP	--
0380 000492	DÜRKOPP-ADLER	130.13.142	KK	--
0380 000493	DÜRKOPP-ADLER	130.13.146	KK	--
0380 000508	DÜRKOPP-ADLER	130.13.143	KP	
0380 008104	DÜRKOPP-ADLER	130.13.157	KK	NBL
0380 008962	DÜRKOPP-ADLER	130.13.143	KP	
0381 150204 DC20	DÜRKOPP-ADLER	130.13.173DC20	KK	NBL
0381 150254	DÜRKOPP-ADLER	130.13.180	KP	
0396 150784	DÜRKOPP-ADLER	130.06.084	KP	--
0396 150814 w/o BC	DÜRKOPP-ADLER	130.05.205	KH	
0396 150824	DÜRKOPP-ADLER	130.06.164	KP	MF
0396 150914 w/o BC	DÜRKOPP-ADLER	130.05.369	KH	
0396 152814 w/o BC	DÜRKOPP-ADLER	130.05.061	KH	
0467 150014	DÜRKOPP-ADLER	130.13.265	KL	NBL
0467 150014 with Cap	DÜRKOPP-ADLER	130.13.298	KK	NBL
0467 150094	DÜRKOPP-ADLER	130.13.251	KL	NBL
0467 150094 DC10	DÜRKOPP-ADLER	130.13.251DC10	KL	NBL
0467 150094 DC20	DÜRKOPP-ADLER	130.13.251DC20	KL	NBL
0467 150094 with Cap	DÜRKOPP-ADLER	130.13.294	KK	NBL
0467 150104	DÜRKOPP-ADLER	130.13.258	KL	NBL
0467 150494	DÜRKOPP-ADLER	130.13.261	KL	NBL
0467 150804	DÜRKOPP-ADLER	130.13.255	KL	NBL
0467 150804 DC10 with Needle Guard	DÜRKOPP-ADLER	130.13.289DC10	KL	NBL
0467 150804 with Needle Guard	DÜRKOPP-ADLER	130.13.289	KL	NBL

Original Number	Original Number of	CM CERLIANI Article Number	Line	NBL Type
0467 150854	DÜRKOPP-ADLER	130.13.255	KL	NBL
0467 150854 DC10 with Needle Guard	DÜRKOPP-ADLER	130.13.289DC10	KL	NBL
0467 150854 with Needle Guard	DÜRKOPP-ADLER	130.13.289	KL	NBL
0491 012041	DÜRKOPP-ADLER	130.13.020	KK	NBL
05 17 0002	ATTILIO FORTE	130.11.165	KL	
05 17 0005	ATTILIO FORTE	130.08.304	KK	--
05 17 0006	ATTILIO FORTE	130.08.000	KK	--
05 17 0007	ATTILIO FORTE	130.08.688	KK	NBL
05 17 0008	ATTILIO FORTE	130.08.100	KK	--
05 17 0009	ATTILIO FORTE	130.08.682	KK	NBL
05 17 0010	ATTILIO FORTE	130.03.017	KH	
05 17 0011	ATTILIO FORTE	130.09.000	KH	
05 17 0014	ATTILIO FORTE	130.08.319	KK	--
05 17 0016	ATTILIO FORTE	130.08.497	KK	
05 17 0017	ATTILIO FORTE	130.08.499	KP	
05 17 0029	ATTILIO FORTE	130.08.240	KK	--
050210140016	TAJIMA	130.01.408	KH	
050210140016 DC20	TAJIMA	130.01.408DC20	KH	
050210210014	TAJIMA	130.01.408	KH	
05022007J013	TAJIMA	130.09.150	KH	
05022009J016	TAJIMA	130.09.150	KH	
05022009J016 TS	TAJIMA	130.09.150TS	KH	
05022010J000	TAJIMA	130.09.150TS	KH	
0549 001491	DÜRKOPP-ADLER	130.13.161	KK	--
0570 001241A w/o BC	DÜRKOPP-ADLER	115.00.209	KH	
0570 001242	DÜRKOPP-ADLER	115.00.209	KH	
0570 001243/A	DÜRKOPP-ADLER	115.00.218	KP	MF
060581 w/o BC	GLOBAL	130.03.057	KH	
065 00 185 4	DÜRKOPP-ADLER	112.00.025	KK	
0667 155604	DÜRKOPP-ADLER	130.13.350	KL	NBL
0667 155604 for HM	DÜRKOPP-ADLER	130.13.370	KL	NBL
0667 155604Heavy Thread	DÜRKOPP-ADLER	130.13.370	KL	NBL
0667 155634	DÜRKOPP-ADLER	130.13.550	KL	NBL
068 15 081 4	DÜRKOPP-ADLER	130.08.343	KK	--
068 15 082 4	DÜRKOPP-ADLER	130.08.341	KK	--
069 00 578 4	DÜRKOPP-ADLER	130.06.106	KP	--
069 00 581 4 w/o BC	DÜRKOPP-ADLER	130.03.040	KH	
069 15 027 4 w/o BC	DÜRKOPP-ADLER	130.03.040	KH	
069 15 028 4	DÜRKOPP-ADLER	130.06.172	KP	MF
069 15 028 4 NBL	DÜRKOPP-ADLER	130.06.320	KP	NBL
0697 004331	DÜRKOPP-ADLER	130.13.165	KK	--
0697 004331 SP	DÜRKOPP-ADLER	130.13.185	KK	--
0697 004331 with Short Gib	DÜRKOPP-ADLER	130.13.185	KK	--
0697 004343	DÜRKOPP-ADLER	130.13.168	KP	
07-001A-5600	SUNSTAR	130.15.050	KL	
07-002A-2700	SUNSTAR	130.06.298	KP	NBL
07-003A-270A	SUNSTAR	130.05.376	KH	
07-003A-270A DC20	SUNSTAR	130.05.376DC20	KH	
07-003A-270A(SP)	SUNSTAR	130.05.527	KH	
07-003A-270B	SUNSTAR	130.05.428	KH	
07-004A-2700	SUNSTAR	130.06.298	KP	NBL
07-005A-5607	GLOBAL	130.15.050	KL	
07-006A-123A	SUNSTAR	130.06.019	KP	--
07-006A-146L	SUNSTAR	130.10.000	KP	--
07-006A-146L MF	SUNSTAR	130.10.007	KP	MF
07-006A-146L NBL	SUNSTAR	130.10.045	KP	NBL
07-007A-123A	SUNSTAR	130.05.235	KH	
07-007A-123A Open Lub.	SUNSTAR	130.05.515	KH	NBL
07-007A-123B	SUNSTAR	130.05.436	KH	
07-007A-146L	SUNSTAR	130.09.226	KH	
07-024A-64L7	SUNSTAR	130.09.186	KH	
07-044A-106C	SUNSTAR	130.13.287	KP	
07-044A-106L	GARUDAN	130.13.251	KL	NBL
07-044A-106L	SUNSTAR	130.13.282	KK	NBL
07-051A-7507	SUNSTAR	130.11.219	KL	
07-052A-7527	GLOBAL	130.19.045	KH	



- 2010 PRODUCTION -

Original Number	Original Number of	CM CERLIANI Article Number	Line	NBL Type	Original Number	Original Number of	CM CERLIANI Article Number	Line	NBL Type
07-052A-75L7	SUNSTAR	130.19.045	KH		105 47651	JUKI	130.08.014	KP	
07-052A-790L	SUNSTAR	130.19.050	KH		105 49855	JUKI	130.08.580	KK	NBL
07-053A-7500	SUNSTAR	130.11.216	KL		105032	SINGER	130.06.065	KP	--
07-054A-750L	SUNSTAR	130.15.128	KL		105490	GLOBAL	130.03.017	KH	
07-055A-7900	SUNSTAR	130.16.053	KH		105490 13.5mm	GLOBAL	130.03.048	KH	
07-056A-7907	SUNSTAR	130.16.059	KH		106 253	PFAFF	130.02.500	KH	
07-056A-7907	SUNSTAR	130.19.050	KH		106 372	PFAFF	130.06.390	KP	--
07-062A-75L7	SUNSTAR	130.20.030	KP	--	106 528	PFAFF	130.06.390	KP	--
07-063A-790L	SUNSTAR	130.20.035	KP	--	10655	SEIKO	130.11.000	KL	
07-064A-7907	SUNSTAR	130.20.040	KP	--	10655-	CONSEW	130.11.000	KL	
07-064A-79L7	SUNSTAR	130.20.040	KP	--	107097-101	BROTHER	130.14.015	KP	NBL
07-065A-7907	SUNSTAR	130.17.030	KP	--	107-22551	JUKI	130.13.251	KL	NBL
07-128A-120H	SUNSTAR	115.00.274	KH		107-22551 with Cap	JUKI	130.13.294	KK	NBL
0767 150194	DÜRKOPP-ADLER	130.13.270	KL	NBL	107-56757	JUKI	130.13.251	KL	NBL
0767 150324	DÜRKOPP-ADLER	130.13.500	KL	NBL	107-56757 with Cap	JUKI	130.13.294	KK	NBL
0767 150324 Heavy material	DÜRKOPP-ADLER	130.13.571L	KL	NBL	10850	PFAFF	130.08.054	KK	--
0767 150324 Heavy Thread	DÜRKOPP-ADLER	130.13.571L	KL	NBL	10896	PFAFF	130.08.304	KK	--
07-S028S-306H-CE	GARUDAN	115.10.013	KH		109471005	YAKUMO(NAKAJIMA)	130.06.380	KP	NBL
07-S032S-306H	SUNSTAR	115.10.013	KH		110017000	NAKAJIMA	130.09.180	KH	
089 00 178 4	DÜRKOPP-ADLER	130.06.110	KP	--	110018000	YAKUMO(NAKAJIMA)	130.10.052	KP	NBL
0891 016041 w/o BC	DÜRKOPP-ADLER	130.09.188	KH		110-38650	JUKI	130.05.376	KH	
0891 16041 w/o BC	DÜRKOPP-ADLER	130.09.188	KH		110-38650	JUKI	130.05.527	KH	
09-029A-7400	SUNSTAR	130.11.078	KL		110-38650 DC20	JUKI	130.05.376DC20	KH	
09-029A-740L	SUNSTAR	130.15.016	KL		110-38759	JUKI	130.06.298	KP	NBL
0935 100141	DÜRKOPP-ADLER	130.13.065	KK	NBL	110525-4-00	NECCHI	130.01.054	KH	
0935 100751	DÜRKOPP-ADLER	130.13.065	KK	NBL	110528-4-00	NECCHI	130.06.056	KP	--
0935 100781	DÜRKOPP-ADLER	130.13.069	KP		11075	SEIKO	130.11.205	KL	
0935 100791	DÜRKOPP-ADLER	130.13.069	KP		110-92251	JUKI	130.05.532	KH	
0935 745210	DÜRKOPP-ADLER	130.13.065	KK	NBL	110-92459	JUKI	130.05.515	KH	NBL
097 00 178 4	DÜRKOPP-ADLER	130.06.019	KP	--	11124	SEIKO	130.11.078	KL	
097 00 178 4 Magnet	DÜRKOPP-ADLER	130.06.351	KP	Magnet	111272-901	BROTHER	130.01.124	KH	
098 15 005 4	DÜRKOPP-ADLER	130.14.015	KP	NBL	111275-001 TS	BROTHER	130.05.517TS	KH	
098 15 007 4	DÜRKOPP-ADLER	130.12.026	KH		111275-901	BROTHER	130.05.271	KH	
1 12 327	ALFA	130.06.069	KP	--	111275-901 open type	BROTHER	130.05.517	KH	
1 12 329	ALFA	130.01.031	KH		111275-901 TS	BROTHER	130.05.517TS	KH	
1 14 213	ALFA	130.05.073	KH		111-41355	JUKI	130.05.477	KH	
1 14 757	ALFA	130.06.128	KP	MF	111-41355 DC10	JUKI	130.05.477DC10	KH	
1 45 500	ALFA	130.08.050	KK	--	112034010 DC20	YAKUMO(NAKAJIMA)	130.05.376DC20	KH	
1 45 507	ALFA	130.08.014	KP		112034010 H Style	YAKUMO(NAKAJIMA)	130.05.376	KH	
1 45 893	ALFA	130.08.304	KK	--	112034010 K Style	YAKUMO(NAKAJIMA)	130.05.424	KH	
100/OC	CERLIANI	120.00.027	KH		112034010(SP)	YAKUMO(NAKAJIMA)	130.05.527	KH	
100369-001	BROTHER	130.06.019	KP	--	112034020 w/o TS Coated	YAKUMO(NAKAJIMA)	130.05.479	KH	
100369-001 Magnet	BROTHER	130.06.351	KP	Magnet	112035000	YAKUMO(NAKAJIMA)	130.06.298	KP	NBL
101-10054 w/o Cap	JUKI	130.16.015	KH		112035000 MF	YAKUMO(NAKAJIMA)	130.06.125	KP	MF
101-10062	JUKI	130.16.015	KH		112041-001	BROTHER	130.01.147	KH	
101-10104	JUKI	130.16.010	KH		112041-901	BROTHER	130.01.147	KH	
101-10153 w/o Cap	JUKI	130.16.010	KH		112691-901	BROTHER	130.11.078	KL	
101-10252	JUKI	130.17.010	KP	--	113190	PFAFF	130.08.462	KK	NBL
101218000	YAKUMO(NAKAJIMA)	130.09.176	KH		113192	PFAFF	130.08.460	KP	
10159	PFAFF	130.08.014	KP		113414	PFAFF	130.08.456	KK	NBL
10159/1	CIUCANI	130.08.491	KP		114 213	ALFA	130.05.073	KH	
10165	PFAFF	130.08.000	KK	--	114 757	ALFA	130.06.128	KP	MF
10165/1	CIUCANI	130.08.478	KK		1144	CONSEW	130.10.039	KP	NBL
101-95154	JUKI	130.11.090	KL		114524-6-02	NECCHI	130.08.405	KK	
101-95154 TTN	JUKI	130.11.090TTN	KL		11498	PFAFF	130.08.070	KP	
101-97655	JUKI	130.11.135	KL		115035040	YAKUMO(NAKAJIMA)	130.09.207	KH	
10231553	JUKI	130.20.045	KP	--	11540-4-00	NECCHI	112.00.031	KK	
102-31553	JUKI	130.20.045	KP	--	115470 005	YAKUMO(NAKAJIMA)	130.10.045	KP	NBL
103109010	YAKUMO(NAKAJIMA)	130.01.124	KH		115470 005 MF	YAKUMO(NAKAJIMA)	130.10.007	KP	MF
103109020	YAKUMO(NAKAJIMA)	130.01.000	KH		116072001	YAKUMO(NAKAJIMA)	130.11.165	KL	
104114010	YAKUMO(NAKAJIMA)	130.05.271	KH		116072001	YAKUMO(NAKAJIMA)	130.11.165R	KL	
104114010	YAKUMO(NAKAJIMA)	130.05.517	KH		1166	CONSEW	130.05.235	KH	
104114010 TS	YAKUMO(NAKAJIMA)	130.05.517TS	KH		1166	CONSEW	130.05.515	KH	NBL
104114020	YAKUMO(NAKAJIMA)	130.05.235	KH		1166 TS	CONSEW	130.05.235TS	KH	
104114020	YAKUMO(NAKAJIMA)	130.05.515	KH	NBL	1166 TTN	CONSEW	130.05.235TTN	KH	
104114020 TS	YAKUMO(NAKAJIMA)	130.05.235TS	KH		116728000	YAKUMO(NAKAJIMA)	130.08.900	KK	--
104507000	YAKUMO(NAKAJIMA)	130.09.000	KH		116780-901	BROTHER	130.05.235	KH	
105 45358	JUKI	130.08.460	KP		116780-901	BROTHER	130.05.515	KH	NBL
					116780-901 TS	BROTHER	130.05.235TS	KH	



Original Number	Original Number of	CM CERLIANI Article Number	Line	NBL Type
117074005	YAKUMO(NAKAJIMA)	130.15.010	KL	
117074005 Reg.needle guard	YAKUMO(NAKAJIMA)	130.15.010R	KL	
117596-001 NBL	BROTHER	130.06.240	KP	NBL
117596-001 NO NBL	BROTHER	130.06.348	KP	--
117677-901	BROTHER	130.01.135	KH	
118318	PFAFF	130.08.546	KK	NBL
118414	PFAFF	130.08.544	KP	
118419	PFAFF	130.08.540	KK	NBL
118875	PFAFF	130.08.534	KK	NBL
118876	PFAFF	130.08.537	KK	NBL
118961-901	BROTHER	130.05.015	KH	
119385	PFAFF	130.08.518	KK	
119386	PFAFF	130.08.319	KK	--
119458	PFAFF	130.08.522	KP	--
119767	PFAFF	130.08.451	KK	--
119899	PFAFF	130.08.524	KK	--
12032	CONSEW	130.11.065	KL	
12032	SEIKO	130.11.075	KL	
12032-	CONSEW	130.11.075	KL	
120631 w/o oil pan/BC	PFAFF	130.12.019	KH	
120710 w/o BC	PFAFF	130.12.019	KH	
121524-4 w/o BC	NECCHI	130.05.246	KH	
122089006	YAKUMO(NAKAJIMA)	130.08.758	KK	
12355	SEIKO	130.16.025	KH	
12393	SINGER	115.00.110	KH	
12530	SEIKO	130.11.187	KL	
12530-	CONSEW	130.11.187	KL	
127119	SINGER	130.01.124	KH	
127119FG	SINGER	130.01.000	KH	
127119JP	SINGER	130.02.000	KH	
127239	SINGER	130.01.000	KH	
127239	SINGER	130.01.018	KH	
127239JP	SINGER	130.02.000	KH	
127239ZZ	SINGER	130.01.046	KH	
127239ZZ	OMAC	130.01.109	KH	
127239ZZJP	SINGER	130.02.030	KH	
127329JP	SINGER	130.02.018	KH	
12781	PFAFF	130.08.530	KK	NBL
12782	PFAFF	130.08.973	KK	NBL
130.06.061 CM Art. Replaced	CERLIANI	130.06.056	KP	--
130.06.201 CM Art. Replaced	CERLIANI	130.06.056	KP	--
130.06.237 CM Art. Replaced	CERLIANI	130.06.056	KP	--
130.06.292 CM Art. Replaced	CERLIANI	130.06.056	KP	--
130.08.178 Ex.Art.CM	CERLIANI	130.08.135	KP	--
130.08.737 Ex.Art.CM	CERLIANI	130.13.024	KK	NBL
13086	SEIKO	130.11.076	KL	
13086-	CONSEW	130.11.076	KL	
135 660	KSM	130.09.084	KH	
135 672	KSM	130.10.061	KP	NBL
136 939	KSM	130.09.084	KH	
136 970 DC20	KSM	130.09.168DC20	KH	
137117	PFAFF	115.00.074	KH	
137A	CONSEW	130.10.050	KP	NBL
137A MF	CONSEW	130.10.013	KP	MF
14005	SEIKO	130.15.075	KL	
14005-	CONSEW	130.15.075	KL	
140287	PFAFF	130.08.674	KP	NBL
140451	PFAFF	130.08.680	KK	NBL
140454	PFAFF	130.08.548	KK	NBL
140538	PFAFF	130.08.273	KK	NBL
140539	GLOBAL	130.08.280	KK	NBL
140539 Extra-heavy duty	GLOBAL	130.08.294	KK	NBL
140540	PFAFF	130.08.678	KK	NBL
140541	PFAFF	130.08.283	KK	NBL
140542	PFAFF	130.08.288	KK	NBL

Original Number	Original Number of	CM CERLIANI Article Number	Line	NBL Type
140543	PFAFF	130.08.553	KK	NBL
140544	PFAFF	130.08.556	KK	NBL
140545	PFAFF	130.08.558	KK	NBL
140650	PFAFF	130.08.495	KP	
14119 W/Cap	SEIKO	130.08.919	KK	--
141307-901	BROTHER	130.12.091	KH	
14175 W/Cap	SEIKO	130.08.919	KK	--
14192	PFAFF	130.08.560	KK	
142019	SINGER	130.01.126	KH	
142019FG	SINGER	130.01.018	KH	
142020	SINGER	130.01.126	KH	
142020FG	SINGER	130.01.018	KH	
143342	SINGER	130.05.000	KH	
143342 Tacking gib	SINGER	130.05.250	KH	
143342FG	SINGER	130.05.235	KH	
143342FG	SINGER	130.05.515	KH	NBL
143342FG 3 Hub Screw	SINGER	130.05.350	KH	
143342FG TS	SINGER	130.05.235TS	KH	
143342FGSN	SINGER	130.05.028	KH	
143342SGO	SINGER	130.05.517	KH	
143342SGOTS	SINGER	130.05.517TS	KH	
143342SN	SINGER	130.05.008	KH	
143342SP	SINGER	130.05.492	KH	
143342STGOTR	SINGER	130.05.521	KH	
143342-Tacking gib	CONSEW	130.05.250	KH	
143390	SINGER	130.06.300	KP	NBL
143390 MF	SINGER	130.06.135	KP	MF
143784-901	BROTHER	130.05.015	KH	
143986-901	BROTHER	130.12.091	KH	
144-36257	JUKI	130.10.500	KP	NBL
144830	SINGER	130.01.124	KH	
144830FG	SINGER	130.01.000	KH	
144903-901	BROTHER	130.11.116	KL	
145 500	ALFA	130.08.050	KK	--
145 507	ALFA	130.08.014	KP	
145 893	ALFA	130.08.304	KK	--
14505	SEIKO	130.15.064	KL	
14505-	CONSEW	130.15.064	KL	
14706	SEIKO	130.19.000	KH	
147069C	SEIKO	130.20.020	KP	--
14706-9C	SEIKO	130.20.020	KP	--
147149	SINGER	130.06.346	KP	--
147789-901	BROTHER	130.09.226	KH	
147790-001	BROTHER	130.10.045	KP	NBL
147790-001 MF	BROTHER	130.10.007	KP	MF
147790-001 NO NBL	BROTHER	130.10.000	KP	--
148350-101	BROTHER	130.06.298	KP	NBL
148350-101 MF	BROTHER	130.06.125	KP	MF
148846-901	BROTHER	130.05.428	KH	
149063	SINGER	130.06.036	KP	--
1500-2-04	NECCHI	115.00.130	KH	
15035LB	YAKUMO(NAKAJIMA)	130.09.207	KH	
150371-901	BROTHER	130.16.000	KH	
15040	SEIKO	130.15.050	KL	
15040	SEIKO	130.15.155	KL	
15040 CONSEW	CONSEW	130.15.050	KL	
150487-901	BROTHER	130.09.176	KH	
1505-4-00	NECCHI	115.00.180	KP	--
1505-4-01	NECCHI	115.00.180	KP	--
150877-901	BROTHER	130.09.176	KH	
150966-901	BROTHER	130.15.050	KL	
151016-901	BROTHER	130.11.201	KL	
151041-001	BROTHER	130.17.000	KP	--
151845-001	BROTHER	130.10.045	KP	NBL
151845-001	BROTHER	130.10.048	KP	NBL
151845-001 MF	BROTHER	130.10.007	KP	MF
15232	SEIKO	130.15.155	KL	
152685-001	BROTHER	115.00.275	KH	
152685-301	BROTHER	115.00.275	KH	
152687-001	BROTHER	115.00.276	KH	



- 2010 PRODUCTION -

Original Number	Original Number of	CM CERLIANI Article Number	Line	NBL Type	Original Number	Original Number of	CM CERLIANI Article Number	Line	NBL Type
152687-201	BROTHER	115.00.276	KH		171820 metric screws w/o BC	PFAFF	130.04.000	KH	
15277	SINGER	115.00.019	KP	--	171910 metric screws	PFAFF	130.04.000	KH	
15277/B	SINGER	115.00.050	KP	--	173058	SINGER	130.06.056	KP	--
153131-001	BROTHER	130.05.424	KH		173239	SINGER	130.01.049	KH	
153131-901	BROTHER	130.05.424	KH		173239	SINGER	130.01.052	KH	
153525-4-00	NECCHI	130.05.079	KH		173239N	SINGER	130.01.054	KH	
153912-901	BROTHER	130.15.061	KL		173240	PFAFF	130.08.585	KK	NBL
15502	SEIKO	130.15.061	KL		174045	SINGER	130.01.139	KH	
15502-	CONSEW	130.15.061	KL		174046 w/o BC	SINGER	130.01.139	KH	
155466-901	BROTHER	130.19.015	KH		174955	PFAFF	130.06.373	KP	NBL
155476-001	BROTHER	130.20.010	KP	--	176369	PFAFF	130.08.660	KK	NBL
156514-901	BROTHER	130.15.090	KL		176440	PFAFF	130.22.510	KL	NBL
157853-901	BROTHER	130.09.207	KH		176442	PFAFF	130.22.515	KL	NBL
157853-901 TTN	BROTHER	130.09.207TTN	KH		178081 NBL	PEGASUS	130.14.015	KP	NBL
15847-001	BROTHER	130.12.051	KH		178081 NO NBL	PEGASUS	130.14.010	KP	--
15847-001 TTN	BROTHER	130.12.051TTN	KH		178081000009 NBL	PEGASUS	130.14.015	KP	NBL
158471-000	BROTHER	130.14.021	KP	NBL	178081000009 NO NBL	PEGASUS	130.14.010	KP	--
158471-001	BROTHER	130.14.017	KP	--	179077	PEGASUS	130.12.026	KH	
15850	SEIKO	130.19.040	KH		179077000009	PEGASUS	130.12.026	KH	
15850-	CONSEW	130.19.040	KH		18.9145.20	C.M.C.I.	130.10.028	KP	MF
15850-09	SEIKO	130.20.020	KP	--	18.9145.50	C.M.C.I.	130.03.017	KH	
158509C	SEIKO	130.20.020	KP	--	18.9145.70	C.M.C.I.	130.06.172	KP	MF
15850-9C	SEIKO	130.20.020	KP	--	18033	SEIKO	130.09.123	KH	
15875	CONSEW	130.11.078	KL		18033-	CONSEW	130.09.123	KH	
159155-001 w/o BC	BROTHER	130.12.084	KH		18045 MF	SEIKO	130.10.037	KP	MF
159156-901	BROTHER	130.12.084	KH		18045 MF-	CONSEW	130.10.037	KP	MF
159793-901	BROTHER	130.09.082	KH		18045 NBL	SEIKO	130.10.052	KP	NBL
159793-901 SG	BROTHER	130.09.228	KH		18045 NBL-	CONSEW	130.10.052	KP	NBL
160130 Exec. w/o Thread Guard	PFAFF	130.14.007	KP	NBL	18099	SEIKO	130.10.050	KP	NBL
160130 NO NBL	PFAFF	130.14.000	KP	--	18-10842	J.A.M.	130.09.152	KH	
162632	PFAFF	130.08.957	KP		18-10842 FB	J.A.M.	130.09.214	KH	
16291	SEIKO	130.16.000	KH		18-10842 Heavy material	J.A.M.	130.09.231	KH	
16291-	CONSEW	130.16.000	KH		18112	PFAFF	130.08.667	KK	
16291-06	SEIKO	130.17.000	KP	--	18113	PFAFF	130.08.676	KK	NBL
16407	SEIKO	130.19.035	KH		18284	PFAFF	130.08.707	KK	NBL
16407-	CONSEW	130.19.035	KH		18285	PFAFF	130.08.697	KK	NBL
164079C	SEIKO	130.20.020	KP	--	18340	PFAFF	130.08.100	KK	--
16407-9C	SEIKO	130.20.020	KP	--	18348	PFAFF	130.08.109	KP	
164900	PFAFF	130.08.950	KK	NBL	18482	PFAFF	130.08.703	KK	NBL
164920	PFAFF	130.22.522	KL	NBL	18550	SEIKO	130.10.000	KP	--
1650-518	SINGER	130.09.082	KH		18550 MF	SEIKO	130.10.007	KP	MF
1650-518 SG	SINGER	130.09.228	KH		18550 NBL	SEIKO	130.10.045	KP	NBL
1650-519	VI.BE.MAC	130.10.048	KP	NBL	18676	PFAFF	130.08.701	KP	NBL
1650-519 MF	VI.BE.MAC	130.10.015	KP	MF	18680	PFAFF	130.08.670	KK	NBL
1650-906	VI.BE.MAC	130.09.082	KH		18849	SEIKO	130.09.006	KH	
1650-906 SG	VI.BE.MAC	130.09.228	KH		18849	SEIKO	130.09.176	KH	
1650-907	VI.BE.MAC	130.10.048	KP	NBL	18849-	CONSEW	130.09.176	KH	
1650-909	VI.BE.MAC	130.09.082	KH		18850	SEIKO	130.10.045	KP	NBL
1650-909 SG	VI.BE.MAC	130.09.228	KH		18850 MF	SEIKO	130.10.007	KP	MF
165800 metric screws w/o BC	PFAFF	130.04.007	KH		18850 NO NBL	SEIKO	130.10.000	KP	--
166733	PFAFF	130.08.960	KK	NBL	18876	PFAFF	130.08.130	KK	--
166900	PFAFF	130.22.516	KL	NBL	18959	PFAFF	130.08.284	KP	
167082 w/o BC	PFAFF	130.23.050	KH		1901 12 00	REFREY	130.08.269	KK	
167084	PFAFF	130.24.050	KP	NBL	1901 12 00/41	REFREY	130.08.261	KK	
167597	PFAFF	130.06.322	KP	NBL	1901 12 60	REFREY	130.08.109	KP	
167600 metric screws w/o BC	PFAFF	130.04.012	KH		1901 12 60/41	REFREY	130.08.267	KP	
167980 w/o BC	PFAFF	130.23.015	KH		1920 12 00	REFREY	130.09.011	KH	
168628	PFAFF	130.24.000	KP	NBL	1920 12 60 MF	REFREY	130.10.007	KP	MF
168885 metric screws w/o BC	PFAFF	130.04.012	KH		1920 12 60 NO NBL	REFREY	130.10.000	KP	--
168888 w/o BC	PFAFF	130.23.000	KH		1930 12 00 w/o BC	REFREY	130.12.122	KH	
17033	SEIKO	130.03.040	KH		1930 12 60	REFREY	130.14.010	KP	--
17033-	CONSEW	130.03.040	KH		19922	PFAFF	130.08.314	KK	--
17034	SEIKO	130.06.294	KP	--	19923	PFAFF	130.08.315	KP	
17034	CONSEW	130.06.320	KP	NBL	19985	SEIKO	130.03.040	KH	
17034 MF	CONSEW	130.06.172	KP	MF	2 11 234	ALFA	130.01.052	KH	
17034 NO NBL	CONSEW	130.06.106	KP	--	2 11 297	ALFA	130.06.056	KP	--
					2 18 210	ALFA	130.06.251	KP	--
					2.11.297	ALFA	130.06.056	KP	--
					2.18210	ALFA	130.06.251	KP	--



Original Number	Original Number of	CM CERLIANI Article Number	Line	NBL Type	Original Number	Original Number of	CM CERLIANI Article Number	Line	NBL Type
201144000	YAKUMO(NAKAJIMA)	130.10.000	KP	--	21245055 W/CAP	JUKI	130.08.791	KK	
20176-4-05	NECCHI	115.00.099	KP	--	212-45055 W/CAP	JUKI	130.08.791	KK	
203072000	YAKUMO(NAKAJIMA)	130.06.019	KP	--	21245154	JUKI	130.08.780	KK	
203072000 Magnet	JAKUMO	130.06.351	KP	Magnet	212-45154	JUKI	130.08.780	KK	
203804	SINGER	130.11.160	KL		21245154 Reg. needle guard	JUKI	130.08.780R	KK	
204524-6-00	NECCHI	130.08.356	KK	--	212-45154 Reg. needle guard	JUKI	130.08.780R	KK	
204524-6-01	NECCHI	130.08.356	KK	--	2130104-300-B	CONSEW	130.09.150	KH	
204524-6-10	NECCHI	130.08.507	KK		2130104-300B Short gib	TOYOTA	130.09.023	KH	
205524-6-00	NECCHI	130.08.370	KK	--	2130104-300B- Short gib	CONSEW	130.09.023	KH	
205524-6-10	NECCHI	130.08.511	KK		2130104-300B TS Short Gib	TOYOTA	130.09.023TS	KH	
205528-4-10	NECCHI	130.08.512	KP		2130104-300B TS- Short Gib	CONSEW	130.09.023TS	KH	
207524-6-00	NECCHI	130.08.374	KK	--	2130104-301A	TOYOTA	130.10.050	KP	NBL
207524-6-10	NECCHI	130.08.501	KK		2130104-301A MF	TOYOTA	130.10.013	KP	MF
210 C	CONSEW	115.00.110	KH		2130504-301	TOYOTA	130.12.051	KH	
21010251	YAKUMO(NAKAJIMA)	130.11.165	KL		2130504-301-	CONSEW	130.12.051	KH	
210-10251	JUKI	130.11.165	KL		2130504-301 TTN	TOYOTA	130.12.051TTN	KH	
210-10251	JUKI	130.11.165R	KL		2130504-301-TTN	CONSEW	130.12.051TTN	KH	
210533	SINGER	130.12.026	KH		2130504-310	TOYOTA	130.12.051	KH	
2110104-301C	TOYOTA	130.06.019	KP	--	2130504-310 TTN	TOYOTA	130.12.051TTN	KH	
2110104-301C-	CONSEW	130.06.019	KP	--	2130704-310A NBL	TOYOTA	130.14.021	KP	NBL
2110104-301C Magnet	CONSEW	130.06.351	KP	Magnet	2130704-310A NO NBL	TOYOTA	130.14.017	KP	--
2110314-310	TOYOTA	130.05.250	KH		213-34552	JUKI	130.15.137	KL	NBL
2110404-310	TOYOTA	130.01.000	KH		213-34552 LAR DC20	JUKI	130.15.137RDC20	KL	NBL
2110404-310	TOYOTA	130.01.124	KH		213-34552 Reg.needle guard	JUKI	130.15.137R	KL	NBL
2110424-310	CONSEW	130.01.000	KH		213-34552 Reg.needle guard DC10	JUKI	130.15.137RDC10	KL	NBL
2110604-301	TOYOTA	130.06.298	KP	NBL	213-87055	JUKI	130.15.183	KL	NBL
2110604-301 MF	TOYOTA	130.06.125	KP	MF	213-87055 Reg.needle guard	JUKI	130.15.183R	KL	NBL
2110604-301B	CONSEW	130.06.298	KP	NBL	2140114-310	TOYOTA	130.11.016	KL	
2110604-301B MF	CONSEW	130.06.125	KP	MF	21431358	JUKI	130.08.780	KK	
2110804-301	TOYOTA	130.10.045	KP	NBL	214-31358	JUKI	130.08.780	KK	
2110804-301 MF	TOYOTA	130.10.007	KP	MF	21431358 Reg. needle guard	JUKI	130.08.780R	KK	
2110804-301 MF-	CONSEW	130.10.007	KP	MF	214-31358 Reg. needle guard	JUKI	130.08.780R	KK	
2110814-310	TOYOTA	130.09.176	KH		21431457	JUKI	130.22.035	KL	NBL
2110904-310	TOYOTA	130.05.436	KH		214-31457	JUKI	130.22.035	KL	NBL
2110904-310-	CONSEW	130.05.436	KH		21431457 Reg. needle guard	JUKI	130.22.035R	KL	NBL
2111104-310(SP)	TOYOTA	130.05.527	KH		214-31457 Reg. needle guard	JUKI	130.22.035R	KL	NBL
2111104-310C	TOYOTA	130.05.376	KH		214-31606	JUKI	130.08.766	KP	
2111104-310C DC20	TOYOTA	130.05.376DC20	KH		21435458	JUKI	130.22.039	KL	NBL
2111704-310(SP)	CONSEW	130.05.527	KH		214-35458	JUKI	130.22.039	KL	NBL
2111704-310C	CONSEW	130.05.376	KH		21435458 Reg. needle guard	JUKI	130.22.039R	KL	NBL
2111704-310C DC20	CONSEW	130.05.376DC20	KH		214-35458 Reg. needle guard	JUKI	130.22.039R	KL	NBL
2113004-310	CONSEW	130.05.235	KH		21435854	JUKI	130.22.034	KL	NBL
2113004-310	CONSEW	130.05.515	KH	NBL	214-35854	JUKI	130.22.034	KL	NBL
2113004-310 TS	CONSEW	130.05.235TS	KH		21435854 Cap System	JUKI	130.08.816R	KK	NBL
2113004-310 TTN	CONSEW	130.05.235TTN	KH		214-35854 Cap System	JUKI	130.08.816R	KK	NBL
211C	CONSEW	115.00.111	KP	--	21435854 Reg. needle guard	JUKI	130.22.034R	KL	NBL
2120304-301	CONSEW	130.10.045	KP	NBL	214-35854 Reg. needle guard	JUKI	130.22.034R	KL	NBL
2120304-301 MF	CONSEW	130.10.007	KP	MF	21441753	JUKI	130.22.028	KL	NBL
2120304-301 NO NBL	CONSEW	130.10.000	KP	--	214-41753	JUKI	130.22.028	KL	NBL
2120304-301C	TOYOTA	130.10.000	KP	--	21441753 Reg. needle guard	JUKI	130.22.028R	KL	NBL
2120304-301C-	CONSEW	130.10.000	KP	--	214-41753 Reg. needle guard	JUKI	130.22.028R	KL	NBL
2120304-310A	CONSEW	130.09.000	KH		216010-310-B	TOYOTA	130.01.399	KH	
2120304-310B	TOYOTA	130.09.000	KH		2160104-310-BTS	TOYOTA	130.01.399TS	KH	
2120604-310	TOYOTA	130.05.235	KH						
2120604-310	TOYOTA	130.05.515	KH	NBL					
2120604-310 TS	TOYOTA	130.05.235TS	KH						
2121414-310	TOYOTA	130.15.061	KL						
2121604-310B	CONSEW	130.05.015	KH						
2121614-310	TOYOTA	130.05.428	KH						
2121614-310-	CONSEW	130.05.428	KH						
21228051 W/Cap	JUKI	130.08.758	KK						
212-28051 W/Cap	JUKI	130.08.758	KK						
212-29356	JUKI	130.08.109	KP						
212-29356 with window	JUKI	130.08.766	KP						
21229752 W/Cap	JUKI	130.08.776	KK						
212-29752 W/Cap	JUKI	130.08.776	KK						
21229752 W/Cap Reg. needle guard	JUKI	130.08.776R	KK						
212-29752 W/Cap Reg. needle guard	JUKI	130.08.776R	KK						



- 2010 PRODUCTION -

Original Number	Original Number of	CM CERLIANI Article Number	Line	NBL Type
2161914-310	TOYOTA	130.01.408	KH	
2161914-310 DC20	TOYOTA	130.01.408DC20	KH	
2161914-310 TS	TOYOTA	130.01.408TS	KH	
2-18-210	ALFA	130.06.251	KP	--
221524-4-00	NECCHI	130.05.246	KH	
221524-4-02 w/o BC	NECCHI	130.05.160	KH	
221525-4-00	NECCHI	130.05.160	KH	
221525-4-00	NECCHI	130.05.246	KH	
221525-4-00	NECCHI	130.05.343	KH	
222098000	YAKUMO(NAKAJIMA)	130.15.010	KL	
222098000 Reg.needle guard	YAKUMO(NAKAJIMA)	130.15.010R	KL	
222528-4-00	NECCHI	130.06.159	KP	MF
224016	SINGER	130.11.062	KL	
224441 NBL	SINGER	130.14.015	KP	NBL
224441 NO NBL	SINGER	130.14.010	KP	--
224459 with Cap	SINGER	130.12.026	KH	
224460	SINGER	130.12.026	KH	
225912-4-00	NECCHI	130.06.258	KP	MF
226-12055	JUKI	130.11.188	KL	
226-12055	JUKI	130.11.216	KL	
226-12659	JUKI	130.17.035	KP	--
226-12758 w/o Cap	JUKI	130.16.055	KH	
226-88105	JUKI	130.17.040	KP	--
226-88154	JUKI	130.17.040	KP	--
226-88253 w/o Cap	JUKI	130.16.053	KH	
227525-4-00	NECCHI	130.09.052	KH	
227526-4-00	NECCHI	130.10.028	KP	MF
228-13455	JUKI	130.15.128	KL	
228-14255 w/o Cap	JUKI	130.19.050	KH	
228-19452 w/o Cap	JUKI	130.19.052	KH	
228-19650	JUKI	130.20.055	KP	--
228-27158 w/o Cap	JUKI	130.19.050	KH	
228-27257	JUKI	130.20.050	KP	--
228-31259 w/o Cap	JUKI	130.19.052	KH	
228524-4-04 w/o BC	NECCHI	130.05.160	KH	
228524-4-05 w/o BC	NECCHI	130.05.160	KH	
22TG-012 E	GLOBAL	130.19.030	KH	
230-25059 R	JUKI	130.08.785R	KK	
23025059 Reg. needle guard	JUKI	130.08.785R	KK	
230-25059 Reg. needle guard	JUKI	130.08.785R	KK	
230-25257	JUKI	130.08.659	KP	NBL
23027568 Reg. needle guard	JUKI	130.22.043R	KL	NBL
230-27568 Reg. needle guard	JUKI	130.22.043R	KL	NBL
230-28053 R	JUKI	130.08.751R	KK	
230-28053 R Heavy duty	JUKI	130.22.052R	KL	NBL
230-28053 R,Drop-in	JUKI	130.22.042R	KL	NBL
230-28053 Reg. n-guard Extra-heavy duty	JUKI	130.08.795R	KK	
23028053 Reg.needle guard	JUKI	130.08.751R	KK	
230-28053 Reg.needle guard	JUKI	130.08.751R	KK	
230-28053 Reg.needle guard,Drop-in	JUKI	130.22.042R	KL	NBL
23028053 Reg.needle guard,Heavy duty	JUKI	130.22.052R	KL	NBL
23028061	JUKI	130.08.246	KP	--
230-28061	JUKI	130.08.246	KP	--
23029051 Reg.needle guard	JUKI	130.08.800R	KK	
230-29051 Reg.needle guard	JUKI	130.08.800R	KK	
23029069	JUKI	130.08.651	KP	
230-29069	JUKI	130.08.651	KP	
230414	PFAFF	115.00.280	KH	

Original Number	Original Number of	CM CERLIANI Article Number	Line	NBL Type
230-58555 R	JUKI	130.22.051R	KL	NBL
23058555 Reg.needle guard	JUKI	130.22.051R	KL	NBL
230-58555 Reg.needle guard	JUKI	130.22.051R	KL	NBL
23502	SINGER	115.00.187	KP	NBL
235797 w/o Cap	SINGER	130.16.045	KH	
236121	SINGER	130.11.075	KL	
237204	SINGER	130.11.062	KL	
238250	SINGER	130.11.065	KL	
239727	SINGER	130.09.009	KH	
239728	SINGER	130.10.048	KP	NBL
239728 MF	SINGER	130.10.015	KP	MF
239780	SINGER	130.09.009	KH	
240091	SINGER	130.11.060	KL	
240207	SINGER	130.11.045	KL	
240240	SINGER	130.11.057	KL	
240558	SINGER	130.11.000	KL	
241491	SINGER	130.16.020	KH	
241676	SINGER	130.17.020	KP	--
241691	SINGER	130.16.025	KH	
24423	PFAFF	115.00.262	KP	MF
244521	SINGER	130.11.076	KL	
244711	SINGER	130.11.016	KL	
248445	SINGER	130.11.051	KL	
248463	SINGER	130.11.051	KL	
24900-28143	KSL	130.13.289	KL	NBL
24900-28143 DC10	KSL	130.13.289DC10	KL	NBL
24900-29840	KSL	130.13.289DC10	KL	NBL
249118 w/o Cap	SINGER	130.16.025	KH	
24H8-001A1	GLOBAL	130.11.165	KL	
24H8-001A1	GLOBAL	130.11.165R	KL	
2515	SINGER	115.00.018	KH	
260 10046	IVOMAO	130.09.191	KH	
260 10079	IVOMAO	130.09.191	KH	
26010001	IVOMAO	130.08.050	KK	--
26010002 R Drop-in ver.	IVOMAO	130.22.052R	KL	NBL
26010002 Reg.needle guard	IVOMAO	130.08.795R	KK	
26010003	IVOMAO	130.03.017	KH	
26010004	IVOMAO	130.06.106	KP	--
26010004 MF	IVOMAO	130.06.172	KP	MF
26010004 NBL	IVOMAO	130.06.320	KP	NBL
26010035	IVOMAO	130.08.014	KP	
26010036	IVOMAO	130.08.246	KP	--
26010043	IVOMAO	130.08.319	KK	--
26010045	IVOMAO	130.10.013	KP	MF
26010045 NBL	IVOMAO	130.10.050	KP	NBL
26010046	IVOMAO	130.09.191	KH	
26010056	IVOMAO	130.08.497	KK	
26010062	IVOMAO	130.08.499	KP	
26010079	IVOMAO	130.09.191	KH	
26010080	IVOMAO	130.22.049R	KL	NBL
26010080 Reg.needle guard	IVOMAO	130.22.049R	KL	NBL
26010081	IVOMAO	130.08.478	KK	
26010190	IVOMAO	130.08.909	KK	--
26010196	IVOMAO	130.08.795R	KK	
26010197	IVOMAO	130.22.049R	KL	NBL
262250 w/o BC	PFAFF	130.05.500	KH	
262376	PFAFF	130.05.500	KH	
262377	PFAFF	130.06.378	KP	NBL
262417 DC20 w/o BC	PFAFF	130.05.507DC20	KH	
262418 DC20	PFAFF	130.05.507DC20	KH	
263170	PFAFF	130.08.934	KK	NBL
263171	PFAFF	130.08.944	KP	
263175	PFAFF	130.08.946	KK	NBL
26327 4 00	NECCHI	115.00.098	KH	
26327-0-00	NECCHI	115.00.098	KH	
263378	PFAFF	130.08.944	KP	



Original Number	Original Number of	CM CERLIANI Article Number	Line	NBL Type	Original Number	Original Number of	CM CERLIANI Article Number	Line	NBL Type
263392	PFAFF	130.08.944	KP		344041-4-00	NECCHI	130.14.500	KP	--
263400	PFAFF	130.08.934	KK	NBL	3440414-00	NECCHI	130.14.500	KP	--
263405	PFAFF	130.08.946	KK	NBL	34802	SINGER	130.12.099	KH	
263430	PFAFF	130.08.934	KK	NBL	34802 TTN	SINGER	130.12.099TTN	KH	
263435	PFAFF	130.08.946	KK	NBL	34814	SINGER	130.16.028	KH	
263464 w/o Cap	SINGER	130.16.028	KH		34882 w/o BC	SINGER	130.12.099	KH	
263489	PFAFF	130.08.944	KP		35574	MEISTERGRAMM	130.09.150	KH	
263490	PFAFF	130.08.934	KK	NBL	35574 Short qib	MEISTERGRAMM	130.09.023	KH	
263495	PFAFF	130.08.946	KK	NBL	35574 TS Short Gib	MEISTERGRAMM	130.09.023TS	KH	
264161 w/o Cap	SINGER	130.16.020	KH		35575	MEISTERGRAMM	130.10.050	KP	NBL
264300	PFAFF	130.05.507DC20	KH		35575 MF	MEISTERGRAMM	130.10.013	KP	MF
264310	PFAFF	130.05.507DC20	KH		35872C	SEIKO	130.09.054	KH	
265225 w/o BC	PFAFF	130.04.012	KH		368132	SINGER	130.05.376	KH	
265262 w/o BC	PFAFF	130.04.075	KH		368132 DC20	SINGER	130.05.376DC20	KH	
265265 w/o BC	PFAFF	130.04.094	KH		368132(SP)	SINGER	130.05.527	KH	
265280 w/o BC	PFAFF	130.04.007	KH		37255	SEIKO	130.08.900	KK	--
265345	PFAFF	130.04.007	KH		37255-07	SEIKO	130.08.014	KP	
265346	PFAFF	130.04.012	KH		37256	SEIKO	130.08.904	KK	--
265355	PFAFF	130.23.050	KH		37735	SEIKO	130.08.580	KK	NBL
265356	PFAFF	130.23.000	KH		37735-7C	SEIKO	130.08.460	KP	
265358	PFAFF	130.04.075	KH		378802-8-11	NECCHI	130.12.084	KH	
265359	PFAFF	130.23.052	KH		380524-4-90 w/o BC	SINGER	130.01.357	KH	
265360	PFAFF	130.23.009	KH		380528-4-90	NECCHI	130.06.240	KP	NBL
266130	PFAFF	130.08.805	KK	NBL	387700-3-29 w/o BC	NECCHI	130.12.091	KH	
266150	PFAFF	130.22.516	KL	NBL	387700-3-30	NECCHI	130.14.015	KP	NBL
266504	PFAFF	130.22.516	KL	NBL	387702-8-10	NECCHI	130.12.091	KH	
266683	PFAFF	130.08.814	KP	NBL	387702-8-11	NECCHI	130.12.084	KH	
266685	PFAFF	130.08.805	KK	NBL	40028	SINGER	115.00.129	KH	
266786	PFAFF	130.22.519	KL	NBL	40028 chromium plated	SINGER	115.00.233	KH	
267357	SINGER	130.11.016	KL		40028-003	SINGER	115.00.233	KH	
268093 w/o BC	PFAFF	130.23.052	KH		40028FC	SINGER	115.00.233	KH	
268674 w/o BC	PFAFF	130.23.000	KH		40038731	JUKI	130.22.043R	KL	NBL
269243	PFAFF	130.14.027	KP	NBL	400-38731 R	JUKI	130.22.043R	KL	NBL
269245 w/o BC	PFAFF	130.12.166	KH		400-38731 Reg. needle guard	JUKI	130.22.043R	KL	NBL
269629	PFAFF	130.12.166	KH		410019	SINGER	130.01.129	KH	
272138	SINGER	130.05.015	KH		410025	SINGER	130.06.233	KP	NBL
272138 SN	SINGER	130.05.028	KH		410025 NO NBL	SINGER	130.06.209	KP	--
275091	SINGER	130.06.046	KP	--	41020	SEIKO	130.09.223	KH	
279	STAGER	130.01.135	KH		412307	SINGER	130.15.010	KL	
279	CONSEW	130.01.148	KH		412307 Reg.needle guard	SINGER	130.15.010R	KL	
281081	SINGER	130.16.062	KH		412309	SINGER	130.15.010	KL	
281776	SINGER	115.10.000	KH		412309 Reg.needle guard	SINGER	130.15.010R	KL	
282522	SINGER	115.10.001	KH		412433 w/o Cap	SINGER	130.16.050	KH	
284 NBL	STAGER	130.06.240	KP	NBL	412440	SINGER	130.17.000	KP	--
284 NO NBL	STAGER	130.06.348	KP	--	414126	SINGER	130.05.151	KH	
29474 AC	UNION SPECIAL	130.11.068	KL		414126	SINGER	130.05.235	KH	
29474 H	UNION SPECIAL	130.11.068	KL		414424	SINGER	130.05.271	KH	
30HG-001A	GLOBAL	130.05.376	KH		414424 open type	SINGER	130.05.517	KH	
30HG-001A DC20	GLOBAL	130.05.376DC20	KH		414424 TS	SINGER	130.05.517TS	KH	
30HG-001A(SP)	GLOBAL	130.05.527	KH		414430	SINGER	130.05.416	KH	
317.008.245 w/o BC	BERNINA	130.12.501	KH	--	417664	SINGER	130.12.051	KH	
317.009.242	BERNINA	130.12.501	KH	--	417664 TTN	SINGER	130.12.051TTN	KH	
317.009.245	BERNINA	130.12.501	KH	--	417A	CONSEW	130.05.376	KH	
317.016.14	BERNINA	130.14.500	KP	--	417A DC20	CONSEW	130.05.376DC20	KH	
317.016.140	BERNINA	130.14.500	KP	--	418045	SINGER	115.00.285	KH	
32388	SINGER	130.05.151	KH		418047	SINGER	115.00.277	KP	--
32644 DC20	MELCO	130.01.430DC20	KH		43725	SINGER	115.00.248	KP	--
3292990113	RESTA	130.09.143	KH		464078	SEIKO	130.15.181	KL	
3292990114	RESTA	130.09.097	KH		470113	SEIKO	130.15.178	KL	
3292990114 FB standard	RESTA	130.09.205	KH		48-1125-5-705	AMF-REECE	130.15.030	KL	
3292990114 NOISELESS	RESTA	130.09.097L	KH		486738	SEIKO	130.08.580	KK	NBL
33G8-001A3B	GLOBAL	130.19.010	KH		502530 NBL	SINGER	130.14.021	KP	NBL
34041	SEIKO	130.15.181	KL		502530 NO NBL	SINGER	130.14.017	KP	--
34075	SEIKO	130.15.181	KL		5-0258	GLOBAL	115.00.273	KH	
34104	SEIKO	130.15.178	KL		502718	SINGER	130.12.051	KH	
34110	SEIKO	130.15.178	KL		502718 TTN	SINGER	130.12.051TTN	KH	
34199201	MELCO	130.01.399	KH		509083 TTN w/o cobalt point	SINGER	130.12.099TTN	KH	
341992-05	MELCO	130.09.150	KH		509083 w/o cobalt point	SINGER	130.12.099	KH	
344040-4-00 w/o BC	NECCHI	130.12.501	KH	--					
3440404-00 w/o BC	NECCHI	130.12.501	KH	--					



- 2010 PRODUCTION -

Original Number	Original Number of	CM CERLIANI Article Number	Line	NBL Type	Original Number	Original Number of	CM CERLIANI Article Number	Line	NBL Type
510008	SINGER	130.15.040	KL		61407B	UNION SPECIAL	130.05.252	KH	
513170	SINGER	130.05.242	KH		61407B TS	UNION SPECIAL	130.05.252TS	KH	
52089	SINGER	130.01.126	KH		61407BFG	UNION SPECIAL	130.05.035	KH	
52089FG	SINGER	130.01.018	KH		61407BFG TS	UNION SPECIAL	130.05.035TS	KH	
52089JP	SINGER	130.02.018	KH		61407BFGSN	UNION SPECIAL	130.05.050	KH	
522 980 008 190	MINERVA	130.11.170	KL		61407BSN	UNION SPECIAL	130.05.050	KH	
522 980 008 235	MINERVA	130.05.412	KH		61407BTS	UNION SPECIAL	130.05.252TS	KH	
522 980 008 290	MINERVA	130.11.180	KL		61413E	UNION SPECIAL	130.06.071	KP	--
522 980 081 067	MINERVA	130.06.036	KP	--	61413E MF	UNION SPECIAL	130.06.178	KP	MF
52237	SINGER	130.06.019	KP	--	61413E NBL	UNION SPECIAL	130.06.304	KP	NBL
52237 Magnet	SINGER	130.06.351	KP	Magnet	62740	SINGER	115.00.111	KP	--
52237 MF	SINGER	130.06.125	KP	MF	629677 w/o BC	PFAFF	130.23.009	KH	
52237 NBL	SINGER	130.06.298	KP	NBL	629679	PFAFF	130.24.005	KP	NBL
52237ZZ	SINGER	130.06.110	KP	--	63090 w/o BC	PFAFF	130.03.008	KH	
522454	SINGER	130.09.000	KH		63913A	UNION SPECIAL	130.06.342	KP	--
522454	SINGER	130.09.006	KH		642022050	BARATTO	130.30.100	KK	--
522456	SINGER	130.10.000	KP	--	642026050	BARATTO	130.30.120	KP	--
522514 w/o BC	NECCHI	130.01.000	KH		64661	PFAFF	130.03.038	KH	
522540	SINGER	130.05.242	KH		65112	MECA	130.10.510	KP	--
52310-4-00	NECCHI	130.01.097	KH		65112	MECA	X5.130.10.510	KP	--
530198	SINGER	130.10.045	KP	NBL	65112/CLB	MECA	130.10.520	KP	--
530198	SINGER	130.10.048	KP	NBL	65114	MECA	130.09.516	KH	
530198 MF	SINGER	130.10.007	KP	MF	65114/CLB	MECA	130.09.521	KH	
530199	SINGER	130.09.009	KH		6560	PFAFF	115.00.074	KH	
536	STAGER	130.12.150	KH		6560 chromium plated	PFAFF	115.00.257	KH	
536-	CONSEW	130.12.150	KH		665 700	PFAFF	130.09.084	KH	
539	STAGER	130.14.017	KP	--	6694	PFAFF	115.00.076	KH	
54.07.56 w/o BC	BERNINA	130.12.501	KH	--	6694 chromium plated	PFAFF	115.00.269	KH	
54.07.57	BERNINA	130.14.500	KP	--	6843	PFAFF	115.00.087	KP	--
54.07.58	BERNINA	130.12.501	KH	--	7006010061	RESTA	130.03.040	KH	
540735	SINGER	130.06.298	KP	NBL	701-505-004	JANOME	130.05.235	KH	
540735 MF	SINGER	130.06.125	KP	MF	701-505-004	JANOME	130.05.515	KH	NBL
541674	SINGER	130.01.129	KH		701-505-004 TS	JANOME	130.05.235TS	KH	
541674-	TONY	130.01.129	KH		703-504-009	JANOME	130.05.271	KH	
541678	SINGER	130.06.233	KP	NBL	703-504-009	JANOME	130.05.517	KH	
541678 NBL	SINGER	130.06.233	KP	NBL	703-504-009 TS	JANOME	130.05.517TS	KH	
541678 NO NBL	SINGER	130.06.209	KP	--	706-505-009	JANOME	130.09.006	KH	
541968	SINGER	130.01.113	KH		706-506-000	JANOME	130.10.000	KP	--
544745	SINGER	130.06.019	KP	--	712	STAGER	130.09.115	KH	
544745 Magnet	SINGER	130.06.351	KP	Magnet	714	STAGER	130.10.050	KP	NBL
544784	SINGER	130.05.416	KH		714 MF	STAGER	130.10.013	KP	MF
545990	SINGER	130.05.151	KH		714 With NBL	CONSEW	130.10.050	KP	NBL
546794SG	SINGER	130.01.139	KH		75126	YAMATO	130.12.026	KH	
554507	SINGER	130.11.084	KL		753435 w/o BC	PFAFF	130.23.013	KH	
554575-4-00	NECCHI	130.01.031	KH		7570040023	RESTA	130.10.045	KP	NBL
554576-6-00 w/o BC	NECCHI	130.01.031	KH		7570040026	RESTA	130.10.013	KP	MF
554577-4-00	NECCHI	130.06.069	KP	--	761-510-008	JANOME	130.01.000	KH	
554577-4-00	NECCHI	130.06.128	KP	MF	761-511-009	JANOME	130.06.019	KP	--
570.568	ZSK	130.06.397	KP	NBL	761-511-009 MF	JANOME	130.06.125	KP	MF
573.018	ZSK	130.03.043	KH		761-511-009 NBL	JANOME	130.06.298	KP	NBL
573.018 DC20	ZSK	130.03.043DC20	KH		7624000060	RESTA	130.03.017	KH	
573.019	ZSK	130.03.059	KH		772814 w/o BC	SINGER	130.12.501	KH	--
573.019 DC20	ZSK	130.03.059DC20	KH		772814- w/o BC	VIGORELLI	130.12.501	KH	--
573.020	ZSK	130.03.043	KH		772815	SINGER	130.14.500	KP	--
573.020 DC20	ZSK	130.03.043DC20	KH		772815-	VIGORELLI	130.14.500	KP	--
573.031	ZSK	130.03.043DC20	KH		774441 w/o BC	PFAFF	130.04.012	KH	
573.031 w/o special coating	ZSK	130.03.043	KH		774442	PFAFF	130.06.416	KP	NBL
574.051	ZSK	120.00.027	KH		774726 w/o BC	PFAFF	130.04.098	KH	
574.100	ZSK	130.06.260	KP	NBL	820220	BARATTO	130.30.100	KK	--
575.155	ZSK	120.00.027	KH		820260	BARATTO	130.30.120	KP	--
600-03040	KING TEX	130.05.235	KH		8243 NBL	PFAFF	130.14.007	KP	NBL
600-03041	KING TEX	130.06.019	KP	--	8243 NO NBL	PFAFF	130.14.000	KP	--
6016	CONSEW	115.00.018	KH		8250	PFAFF	130.12.001	KH	
6017	CONSEW	115.00.019	KP	--	84020 0266	ALTIN	130.06.036	KP	--
60461	PFAFF	130.03.017	KH		8427 0136	ALTIN	130.05.410	KH	
60482	SEIKO	130.13.291	KL	NBL	8427 0171	ALTIN	130.05.412	KH	
60581 w/o BC	PFAFF	130.03.057	KH		8427 0226	ALTIN	130.05.410	KH	
61207D	UNION SPECIAL	130.05.252	KH		8427 0232	ALTIN	130.05.412	KH	
61207D TS	UNION SPECIAL	130.05.252TS	KH		8-6-1100	MARCO	130.01.131	KH	
					90 12 00	REFREY	130.01.000	KH	



Original Number	Original Number of	CM CERLIANI Article Number	Line	NBL Type	Original Number	Original Number of	CM CERLIANI Article Number	Line	NBL Type
90 12 60	REFREY	130.06.125	KP	MF	91-105 490-91 w/o BC	PFAFF	130.03.017	KH	
901 12 00	REFREY	130.08.482	KK	--	91-106 253-91 w/o BC	PFAFF	130.02.500	KH	
901 12 00/41	REFREY	130.08.470	KK		91-106 372-91	PFAFF	130.06.390	KP	--
901 12 00-P	REFREY	130.08.591	KK	--	91-106 528-91	PFAFF	130.06.390	KP	--
901 12 60	REFREY	130.08.014	KP		91-110 177-91 Hook only	PFAFF	115.00.269	KH	
901 12 60/41	REFREY	130.08.474	KP		91-110 177-91 MF BC only	PFAFF	115.00.262	KP	MF
905 12 00	REFREY	130.09.006	KH		91-113 190-91	PFAFF	130.08.462	KK	NBL
9076	PFAFF	130.06.320	KP	NBL	91-113 192-91	PFAFF	130.08.460	KP	
9076 14mm	PFAFF	130.06.294	KP	--	91-113 414-91	PFAFF	130.08.456	KK	NBL
9076 MF	PFAFF	130.06.172	KP	MF	91-118 318-91	PFAFF	130.08.546	KK	NBL
9076 NO NBL	PFAFF	130.06.106	KP	--	91-118 414-91	PFAFF	130.08.544	KP	
9076-14	PFAFF	130.06.359	KP	--	91-118 419-91	PFAFF	130.08.540	KK	NBL
9078	PFAFF	130.03.013	KH		91-118 875-91	PFAFF	130.08.534	KK	NBL
91 12 00	REFREY	130.05.124	KH		91-118 876-91	PFAFF	130.08.537	KK	NBL
91 12 60	REFREY	130.06.128	KP	MF	91-119 385-91	PFAFF	130.08.518	KK	
91-006 560-05	PFAFF	115.00.074	KH		91-119 386-91	PFAFF	130.08.319	KK	--
91-006 560-45	PFAFF	115.00.257	KH		91-119 458-91	PFAFF	130.08.522	KP	--
91-006 694-05	PFAFF	115.00.076	KH		91-119 767-91	PFAFF	130.08.451	KK	--
91-006 694-45	PFAFF	115.00.269	KH		91-119 899-91	PFAFF	130.08.524	KK	--
91-006 843-91	PFAFF	115.00.087	KP	--	91-120 631-91 w/o oil pan/BC	PFAFF	130.12.019	KH	
91-008 243-91 NBL	PFAFF	130.14.007	KP	NBL	91-120 710-91 w/o BC	PFAFF	130.12.019	KH	
91-008 243-91 NO NBL	PFAFF	130.14.000	KP	--	91-130 117-91 Hook only	PFAFF	115.00.257	KH	
91-008 250-91 w/o BC	PFAFF	130.12.001	KH		91-130 590-91	PFAFF	115.00.229	KP	MF
91-008 250-99	PFAFF	130.12.001	KH		91-132 015-91 Hook only	PFAFF	115.00.074	KH	
91-009 072-91	PFAFF	130.03.014	KH		91-132 016-91 Hook only	PFAFF	115.00.076	KH	
91-009 076-61	PFAFF	130.06.320	KP	NBL	91-132 016-91 MF BC only	PFAFF	115.00.262	KP	MF
91-009 076-61 14mm	PFAFF	130.06.294	KP	--	91-137 117-91	PFAFF	115.00.074	KH	
91-009 076-61 MF	PFAFF	130.06.172	KP	MF	91-140 287-91	PFAFF	130.08.674	KP	NBL
91-009 076-61 NO NBL	PFAFF	130.06.106	KP	--	91-140 451-91	PFAFF	130.08.680	KK	NBL
91-009 078-91	PFAFF	130.03.013	KH		91-140 454-91	PFAFF	130.08.548	KK	NBL
91-009 096-61	PFAFF	130.06.172	KP	MF	91-140 538-91	PFAFF	130.08.273	KK	NBL
91-009 191-91 w/o BC	PFAFF	130.03.000	KH		91-140 539-91	PFAFF	130.08.280	KK	NBL
91-009 264-91 w/o BC	PFAFF	130.03.013	KH		91-140 539-91 Heavy duty	PFAFF	130.08.294	KK	NBL
91-009 268-91 w/o BC	PFAFF	130.03.014	KH		91-140 540-91	PFAFF	130.08.678	KK	NBL
91-010 159-91	PFAFF	130.08.014	KP		91-140 541-91	PFAFF	130.08.283	KK	NBL
91-010 165-91	PFAFF	130.08.000	KK	--	91-140 542-91	PFAFF	130.08.288	KK	NBL
91-010 850-91	PFAFF	130.08.054	KK	--	91-140 543-91	PFAFF	130.08.553	KK	NBL
91-010 896-91	PFAFF	130.08.304	KK	--	91-140 544-91	PFAFF	130.08.556	KK	NBL
91-011 498-51	PFAFF	130.08.070	KP		91-140 545-91	PFAFF	130.08.558	KK	NBL
91-011 498-91	PFAFF	130.08.070	KP		91-140 650-91	PFAFF	130.08.495	KP	
91-012 781-91	PFAFF	130.08.530	KK	NBL	91-160 130-91 Exec. w/o Thread Guard	PFAFF	130.14.007	KP	NBL
91-012 782-91	PFAFF	130.08.973	KK	NBL	91-160 130-91 NO NBL	PFAFF	130.14.000	KP	--
91-013 778-91 W Standard Point	PFAFF	130.08.560	KK		91-162 632-91	PFAFF	130.08.957	KP	
91-014 192-91	PFAFF	130.08.560	KK		91-163 260-91 w/o BC	PFAFF	130.03.048	KH	
91-014 415-91	PFAFF	130.08.965	KK	NBL	91-163 264-91	PFAFF	130.06.294	KP	--
91-018 112-91	PFAFF	130.08.667	KK		91-164 900-91	PFAFF	130.08.950	KK	NBL
91-018 113-91	PFAFF	130.08.676	KK	NBL	91-164 920-91	PFAFF	130.22.522	KL	NBL
91-018 284-91	PFAFF	130.08.707	KK	NBL	91-165 800-91 metric screws w/o BC	PFAFF	130.04.007	KH	
91-018 285-91	PFAFF	130.08.697	KK	NBL	91-166 733-91	PFAFF	130.08.960	KK	NBL
91-018 340-91	PFAFF	130.08.100	KK	--	91-166 900-91	PFAFF	130.22.516	KL	NBL
91-018 348-91	PFAFF	130.08.109	KP		91-167 082-91 w/o BC	PFAFF	130.23.050	KH	
91-018 482-91	PFAFF	130.08.703	KK	NBL	91-167 084-91	PFAFF	130.24.050	KP	NBL
91-018 676-91	PFAFF	130.08.701	KP	NBL	91-167 597-91	PFAFF	130.06.322	KP	NBL
91-018 680-91	PFAFF	130.08.670	KK	NBL	91-167 600-91 metric screws w/o BC	PFAFF	130.04.012	KH	
91-018 876-91	PFAFF	130.08.130	KK	--	91-167 980-91 w/o BC	PFAFF	130.23.015	KH	
91-018 959-91	PFAFF	130.08.284	KP		91-168 628-91	PFAFF	130.24.000	KP	NBL
91-019 922-91	PFAFF	130.08.314	KK	--	91-168 885-91 metric screws w/o BC	PFAFF	130.04.012	KH	
91-019 923-91	PFAFF	130.08.315	KP		91-168 888-91 w/o BC	PFAFF	130.23.000	KH	
91-024 423-91	PFAFF	115.00.262	KP	MF	91-171 820-91 metric screws w/o BC	PFAFF	130.04.000	KH	
91-060 461-91	PFAFF	130.03.017	KH		91-171 820-91 w/o BC	PFAFF	130.04.000	KH	
91-060 581-91 w/o BC	PFAFF	130.03.057	KH		91-171 910-91 metric screws w/o BC	PFAFF	130.04.000	KH	
91-063 090-91 w/o BC	PFAFF	130.03.008	KH						
91-064 661-91 w/o balacing ring	PFAFF	130.03.014	KH						
91-064 661-91 w/o BC	PFAFF	130.03.038	KH						
91-064 662-91 w/o BC	PFAFF	130.03.014	KH						
91-064 662-91 with balacing ring	PFAFF	130.03.038	KH						
91-105 490-91 13.5mm	PFAFF	130.03.048	KH						



- 2010 PRODUCTION -

Original Number	Original Number of	CM CERLIANI Article Number	Line	NBL Type	Original Number	Original Number of	CM CERLIANI Article Number	Line	NBL Type
91-171 910-91 w/o BC	PFAFF	130.04.000	KH		971723-4-00	NECCHI	130.08.135	KP	--
91-173 240-91	PFAFF	130.08.585	KK	NBL	971724-6-01	NECCHI	130.08.180	KK	
91-174 475-91 metric screws w/o BC	PFAFF	130.04.075	KH		971724-6-11	NECCHI	130.08.186	KK	
91-174 703-91 BC only	PFAFF	130.06.373	KP	NBL	971725-6-03	NECCHI	130.08.174	KK	
91-174 955-91	PFAFF	130.06.373	KP	NBL	971735-6-02	NECCHI	130.08.394	KK	--
91-176 369-91	PFAFF	130.08.660	KK	NBL	971828-4-10	NECCHI	130.08.505	KP	
91-176 440-91	PFAFF	130.22.510	KL	NBL	971839-4-00	NECCHI	130.08.183	KP	
91-176 442-91	PFAFF	130.22.515	KL	NBL	971840-6-01	NECCHI	130.08.182	KK	
91-230 413-91 Hook only	PFAFF	115.00.280	KH		971840-6-11	NECCHI	130.08.203	KK	
91-230 414-45	PFAFF	115.00.280	KH		971842-4-00	NECCHI	130.01.111	KH	
91-230 422-91 Hook only	PFAFF	115.00.280	KH		971849-4-00	NECCHI	130.06.056	KP	--
91-230 422-91 MF BC only	PFAFF	115.00.262	KP	MF	971849-4-00 NO NBL	NECCHI	130.06.203	KP	--
91-262 250-91 w/o BC	PFAFF	130.05.500	KH		971861-4-00	NECCHI	130.06.056	KP	--
91-262 376-91	PFAFF	130.05.500	KH		971861-4-00 MF	NECCHI	130.06.056	KP	--
91-262 377-91	PFAFF	130.06.378	KP	NBL	971878-4-00	NECCHI	130.06.108	KP	--
91-262 417-91 DC20 w/o BC	PFAFF	130.05.507DC20	KH		971907-6-01	NECCHI	130.08.197	KK	
91-262 418-91 DC20	PFAFF	130.05.507DC20	KH		971911-4-00	NECCHI	130.05.287	KH	
91-263 170-91	PFAFF	130.08.934	KK	NBL	971912-4-00	NECCHI	130.06.159	KP	MF
91-263 171-91	PFAFF	130.08.944	KP		971913-4-06 w/o BC	NECCHI	130.05.287	KH	
91-263 175-91	PFAFF	130.08.946	KK	NBL	971914-6-00	NECCHI	130.08.248	KK	
91-263 378-91	PFAFF	130.08.944	KP		971915-6-00	NECCHI	130.08.257	KK	
91-263 392-91	PFAFF	130.08.944	KP		971921-6-00	NECCHI	130.08.515	KK	
91-263 400-91	PFAFF	130.08.934	KK	NBL	971923-4-00	NECCHI	130.08.392	KP	
91-263 405-91	PFAFF	130.08.946	KK	NBL	971924-4-00	NECCHI	130.08.411	KP	
91-263 430-91	PFAFF	130.08.934	KK	NBL	971927-4-00	NECCHI	130.08.368	KP	
91-263 435-91	PFAFF	130.08.946	KK	NBL	971928-4-00	NECCHI	130.08.395	KP	
91-263 489-91	PFAFF	130.08.944	KP		971955-4-00	NECCHI	130.12.111	KH	
91-263 490-91	PFAFF	130.08.934	KK	NBL	971956-4-00	NECCHI	130.14.007	KP	NBL
91-263 495-91	PFAFF	130.08.946	KK	NBL	971956-4-00 NO NBL	NECCHI	130.14.000	KP	--
91-264 300-91 w/o BC	PFAFF	130.05.507DC20	KH		971963-4-00	NECCHI	130.12.082	KH	
91-264 310-91	PFAFF	130.05.507DC20	KH		971964-4-00 NBL	NECCHI	130.14.007	KP	NBL
91-265 225-91 w/o BC	PFAFF	130.04.012	KH		971964-4-00 NO NBL	NECCHI	130.14.000	KP	--
91-265 262-91 w/o BC	PFAFF	130.04.075	KH		971989-6-00	NECCHI	130.08.254	KK	
91-265 265-91 w/o BC	PFAFF	130.04.094	KH		98622	SINGER	112.00.031	KK	
91-265 280-91 w/o BC	PFAFF	130.04.007	KH		98624	SINGER	112.00.031	KK	
91-265 345-91	PFAFF	130.04.007	KH		99-135 660-91	KSM	130.09.084	KH	
91-265 346-91	PFAFF	130.04.012	KH		99-135 672-91	KSM	130.10.061	KP	NBL
91-265 355-91	PFAFF	130.23.050	KH		99-136 939-91	KSM	130.09.084	KH	
91-265 356-91	PFAFF	130.23.000	KH		99-136 970-91 DC20	KSM	130.09.168DC20	KH	
91-265 358-91	PFAFF	130.04.075	KH		994485	SEIKO	130.13.291	KL	NBL
91-265 359-91	PFAFF	130.23.052	KH		A133C226G01	MITSUBISHI	130.09.207TTN	KH	
91-265 360-91	PFAFF	130.23.009	KH		A-1830-555-OAO	FOMAX	130.05.376	KH	
91-266 130-91	PFAFF	130.08.805	KK	NBL	A-1830-555-OAO DC20	FOMAX	130.05.376DC20	KH	
91-266 150-91	PFAFF	130.22.516	KL	NBL	A-1830-555-OAO(SP)	FOMAX	130.05.527	KH	
91-266 504-91	PFAFF	130.22.516	KL	NBL	A-1830-555-000	FOMAX	130.05.235	KH	
91-266 683-91	PFAFF	130.08.814	KP	NBL	A-1830-555-000	FOMAX	130.05.515	KH	NBL
91-266 685-91	PFAFF	130.08.805	KK	NBL	A1830-555-000 TS	FOMAX	130.05.235TS	KH	
91-266 786-91	PFAFF	130.22.519	KL	NBL	A-1837-555-000	FOMAX	130.06.019	KP	--
91-268 093-91 w/o BC	PFAFF	130.23.052	KH		A1837-555-000 Magnet	FOMAX	130.06.351	KP	Magnet
91-268 674-91 w/o BC	PFAFF	130.23.000	KH		A190D090P01				
91-269 243-91	PFAFF	130.14.027	KP	NBL	Reg.needle guard w/o Cap	MITSUBISHI	130.19.005R	KH	
91-269 245-91 w/o BC	PFAFF	130.12.166	KH		A190D090P01 w/o Cap	MITSUBISHI	130.19.005	KH	
91-269 629-91	PFAFF	130.12.166	KH		A190D091P01 w/o Cap	MITSUBISHI	130.19.030	KH	
91-629 677-91 w/o BC	PFAFF	130.23.009	KH		A190D305P01	MITSUBISHI	130.09.210	KH	
9191 w/o BC	PFAFF	130.03.000	KH		A190D359P02	MITSUBISHI	130.05.376	KH	
92 12 00	REFREY	130.05.127	KH		A190D359P02 DC20	MITSUBISHI	130.05.376DC20	KH	
9264 w/o BC	PFAFF	130.03.013	KH		A190D522P01	MITSUBISHI	130.09.207	KH	
93 12 00 w/o BC	REFREY	130.12.122	KH		B151845-001	J.A.M.	130.10.007	KP	MF
93 12 60	REFREY	130.14.015	KP	NBL	B1808-761-OAB	JUKI	130.12.068	KH	
95-629 677-91 w/o BC	PFAFF	130.23.009	KH		B1808-761-OAO	JUKI	130.12.068	KH	
95-629 679-91	PFAFF	130.24.005	KP	NBL	B1810-761-OAO	JUKI	130.14.010	KP	--
95-665 700-91	PFAFF	130.09.084	KH		B1810-761-OBA	JUKI	130.14.015	KP	NBL
95-753 435-91 w/o BC	PFAFF	130.23.013	KH		B1818-205-OOB	JUKI	115.10.009	KH	
95-774 441-91 w/o BC	PFAFF	130.04.012	KH		B1818-205-OOO	JUKI	115.10.008	KH	
95-774 442-91	PFAFF	130.06.416	KP	NBL	B1818-210-DOA	JUKI	115.10.006	KH	
95-774 726-91 w/o BC	PFAFF	130.04.098	KH		B1818-210-DOB	JUKI	115.10.007	KH	
971312-6-02	NECCHI	130.08.384	KK	--	B1818-210-OOO	JUKI	115.10.002	KH	
					B1818-280-OOO	JUKI	115.00.273	KH	
					B1828-980-OAB	JUKI	115.00.286	KP	--



Original Number	Original Number of	CM CERLIANI Article Number	Line	NBL Type	Original Number	Original Number of	CM CERLIANI Article Number	Line	NBL Type
B1828-980-OAO	JUKI	115.00.277	KP	--	D1830-141-EAO	JUKI	130.09.207	KH	
B1830-009-OAO	JUKI	130.01.000	KH		D1830-141-EAO-	YAKUMO(NAKAJIMA)	130.09.207	KH	
B1830-027-OAO	JUKI	130.01.135	KH		D1830-415-BAH	JUKI	130.05.428	KH	
B1830-051-OAO	JUKI	130.11.062	KL		D1830-555-BAO	JUKI	130.05.376	KH	
B1830-055-OAO	JUKI	130.11.000	KL		D1830-555-BAO DC20	JUKI	130.05.376DC20	KH	
B1830-127-OAO	JUKI	130.05.235	KH		D1830-555-BAO(SP)	JUKI	130.05.527	KH	
B1830-127-OAO	JUKI	130.05.515	KH	NBL	D1830-555-DAB	JUKI	130.05.473	KH	
B1830-127-OAO TS	JUKI	130.05.235TS	KH		D1830-555-DAC	JUKI	130.05.219	KH	
B1830-141-HAO	JUKI	130.09.176	KH		D1837-555-BAA	JUKI	130.06.298	KP	NBL
B1830-141-HAO-	YAKUMO(NAKAJIMA)	130.09.176	KH		D1837-555-BAA MF	JUKI	130.06.125	KP	MF
B1830-201-OAO	JUKI	130.09.226	KH		EJ-6100-OA	GLOBAL	130.15.024	KL	
B1830-201-SAO	JUKI	130.09.176	KH		EOS	OMAC	130.01.109	KH	
B1830-241-HAO	JUKI	130.09.180	KH		ESMPZ00050	HAPPY	130.01.403	KH	
B1830-241-SAO	JUKI	130.09.176	KH		ESMPZ00050 TS	HAPPY	130.01.403TS	KH	
B1830-245-OAO	JUKI	130.05.496	KH		ESMPZ0050	HAPPY	130.01.399	KH	
B1830-245-OAO-	YAKUMO(NAKAJIMA)	130.05.496	KH		ESMPZ01260	HAPPY	130.01.403TS	KH	
B1830-311-OAO	JUKI	130.22.040	KL	NBL	ESMPZ01360	HAPPY	130.01.408	KH	
B1830-311-OAO-	YAKUMO(NAKAJIMA)	130.22.040	KL	NBL	G111	SIRUBA	130.05.235	KH	
B1830-415-OAO	JUKI	130.05.015	KH		G111 Open Lub.	SIRUBA	130.05.515	KH	NBL
B1830-415-OAO	JUKI	130.05.515	KH	NBL	G111 TS	SIRUBA	130.05.235TS	KH	
B1830-512-OAH	JUKI	130.11.105	KL		G112	SIRUBA	130.05.271	KH	
B1830-512-OAO	JUKI	130.11.101	KL		G112J	SIRUBA	130.05.271	KH	
B1830-521-HAO w/o Cap	JUKI	130.19.025	KH		G112J Open Lub.	SIRUBA	130.05.517	KH	
B1830-521-HAO- w/o Cap	YAKUMO(NAKAJIMA)	130.19.025	KH		G113	SIRUBA	130.05.477	KH	
B1830-521-OAO w/o Cap	JUKI	130.19.020	KH		G113 DC10	SIRUBA	130.05.477DC10	KH	
B1830-528-OAO	JUKI	130.16.050	KH		G121	SIRUBA	130.05.376	KH	
B1830-555-GAO	JUKI	130.05.250	KH		G121	SIRUBA	130.05.527	KH	
B1830-555-HAO	JUKI	130.05.436	KH		G121 DC20	SIRUBA	130.05.376DC20	KH	
B1830-555-UAO	JUKI	130.05.350	KH		G122	SIRUBA	130.05.479	KH	
B1830-563-BAO	JUKI	130.15.010	KL		G122J	SIRUBA	130.05.479	KH	
B1830-563-BAO	JUKI	130.15.010R	KL		G131	SIRUBA	130.09.210	KH	
B1830-563-BAO	JUKI	130.15.010R	KL		G132	SIRUBA	130.09.207	KH	
B1830-563-OAO	JUKI	130.15.000	KL		G135	SIRUBA	130.09.207TTN	KH	
B1830-563-OAO	JUKI	130.15.000R	KL		G151	SIRUBA	130.11.165	KL	
B1837-012-OAO	JUKI	130.06.019	KP	--	G151	SIRUBA	130.11.165R	KL	
B1837-012-OAO Magnet	JUKI	130.06.351	KP	Magnet	G152-A	SIRUBA	130.08.904	KK	--
B1837-027-OAO	JUKI	130.06.348	KP	--	G153-A	SIRUBA	130.08.919	KK	--
B1837-027-OAO NBL	JUKI	130.06.240	KP	NBL	G154-A	SIRUBA	130.08.758	KK	
B1837-201-OAO	JUKI	130.10.000	KP	--	G155-A	SIRUBA	130.08.594	KK	NBL
B1837-211-SAO	JUKI	130.10.045	KP	NBL	G161	SIRUBA	130.11.188	KL	
B1837-211-SAO MF	JUKI	130.10.007	KP	MF	G162	SIRUBA	130.16.054	KH	
B1837-211-SAO NO NBL	JUKI	130.10.000	KP	--	G163	SIRUBA	130.11.195	KL	
B1837-241-HOO	JUKI	130.10.052	KP	NBL	G164	SIRUBA	130.16.060	KH	
B1837-241-HOO-	YAKUMO(NAKAJIMA)	130.10.052	KP	NBL	G165	SIRUBA	130.15.125	KL	
B1837-241-SOO	JUKI	130.10.000	KP	--	G166	SIRUBA	130.19.042	KH	
B1837-245-DAO	JUKI	130.06.380	KP	NBL	G167	SIRUBA	130.11.122	KL	
B1837-245-OAO	JUKI	130.06.380	KP	NBL	G167 w/o special hard treatment	SIRUBA	130.11.131	KL	
B1837-526-OAO	YAKUMO(NAKAJIMA)	130.20.000	KP	--	G168	SIRUBA	130.19.051	KH	
B1837-526-OAO-	YAKUMO(NAKAJIMA)	130.20.000	KP	--	G169	SIRUBA	130.16.052	KH	
B1837-528-OAO	JUKI	130.17.000	KP	--	G170	SIRUBA	130.16.056	KH	
B3003	HAPPY	130.01.399	KH		G171	SIRUBA	130.15.024	KL	
B3003TS	HAPPY	130.01.399TS	KH		G173	SIRUBA	130.15.166	KL	
B49	CONSEW	130.12.051	KH		G175	SIRUBA	130.13.251	KL	NBL
B49 TTN	CONSEW	130.12.051TTN	KH		G175 with Cap	SIRUBA	130.13.294	KK	NBL
B70	CONSEW	130.01.135	KH		G181	SIRUBA	115.10.001	KH	
B75 NBL	CONSEW	130.06.240	KP	NBL	G182	SIRUBA	115.00.276	KH	
B75 NO NBL	CONSEW	130.06.348	KP	--	G201	SIRUBA	130.06.019	KP	--
B79	CONSEW	130.09.115	KH		G202	SIRUBA	130.06.298	KP	NBL
B-814-1 w/o BC	REFREY	130.12.501	KH	--	G202 MF	SIRUBA	130.06.125	KP	MF
B-814-1-930N w/o BC	REFREY	130.12.512	KH	--	G204	SIRUBA	130.10.000	KP	--
B-814-2 w/o BC	REFREY	130.12.501	KH	--	G205	SIRUBA	130.10.045	KP	NBL
B-815-1	REFREY	130.14.500	KP	--	G-400T	GARUDAN	130.08.907	KK	NBL
BD-3292	PFAFF	130.05.537	KH		G401	SIRUBA	130.08.014	KP	
BD3365A	PFAFF	130.06.298	KP	NBL	G401A	SIRUBA	130.08.926	KP	
BR-159155-001 w/o BC	SINGER	130.12.084	KH		G402	SIRUBA	130.08.766	KP	
C06217 w/o Cap	CORNELY	130.16.063	KH		G403	SIRUBA	130.08.460	KP	
C06217 w/o Cap/Washer	CORNELY	130.16.045	KH		G406	SIRUBA	130.17.035	KP	--
CH319995	SINGER	130.11.084	KL		G407	SIRUBA	130.20.035	KP	--
D1818-282-NOO	JUKI	115.00.274	KH		G408	SIRUBA	130.20.040	KP	--



- 2010 PRODUCTION -

Original Number	Original Number of	CM CERLIANI Article Number	Line	NBL Type
G409	SIRUBA	130.17.025	KP	--
G410	SIRUBA	130.17.030	KP	--
G411	SIRUBA	130.20.030	KP	--
GC6-5	CHINESE BRAND	130.09.226	KH	
GP-402	GARUDAN	130.08.588	KK	
GP-406	GARUDAN	130.08.578	KK	NBL
H76-29	ANKER-PHOENIX	120.00.027	KH	
HB220010	BARUDAN	130.09.150	KH	
HB220010 TS	BARUDAN	130.09.150TS	KH	
HE41J07101	HIGHLEAD	130.13.500	KL	NBL
HK111-0002B	KING TEX	130.05.376	KH	
HK111-0002B DC20	KING TEX	130.05.376DC20	KH	
IE 35780	IDEAL	130.10.028	KP	MF
IE 35780PT	IDEAL	130.10.030	KP	MF
IE 35822CH	IDEAL	130.09.059	KH	
IE 35872CT	IDEAL	130.09.054	KH	
JA6100-1A	GOLDEN WHEEL	130.11.165	KL	
JA6100-1A	GOLDEN WHEEL	130.11.165R	KL	
JAB6100-0A	GOLDEN WHEEL	130.08.594	KK	NBL
JB6100-0A	GOLDEN WHEEL	130.11.076	KL	
JB6100-2A	GOLDEN WHEEL	130.11.075	KL	
JC6100-010A	GOLDEN WHEEL	130.11.116	KL	
JC6100-022A	GOLDEN WHEEL	130.15.016	KL	
JC6100-030A	GOLDEN WHEEL	130.11.078	KL	
JC6100-033A	GOLDEN WHEEL	130.16.051	KH	
JC6100-4A	GOLDEN WHEEL	130.11.078	KL	
JD6100-1A	GOLDEN WHEEL	130.16.062	KH	
JD6100-3A	GOLDEN WHEEL	130.19.010	KH	
JD6100-5A	GOLDEN WHEEL	130.16.000	KH	
JD6100-6A	GOLDEN WHEEL	130.16.051	KH	
JD6105-0A	GOLDEN WHEEL	130.17.000	KP	--
JE6100-0A	GOLDEN WHEEL	130.01.124	KH	
JE6100-3A	GOLDEN WHEEL	130.09.006	KH	
JE6105-0A	GOLDEN WHEEL	130.06.019	KP	--
JE6105-0A-	MILLION SPECIAL	130.06.019	KP	--
JE6105-0A Magnet	GOLDEN WHEEL	130.06.351	KP	Magnet
JE6105-3A	GOLDEN WHEEL	130.10.045	KP	NBL
JGN137-8	PFAFF	130.05.537	KH	
JGN138-8	PFAFF	130.06.298	KP	NBL
JJ6100-1A	GOLDEN WHEEL	130.08.904	KK	--
JJ6105-1A	GOLDEN WHEEL	130.08.014	KP	
JL6100-0A	GOLDEN WHEEL	130.01.147	KH	
JL6100-1A	GOLDEN WHEEL	130.03.017	KH	
JL6100-2A	GOLDEN WHEEL	130.03.048	KH	
JL6100-3A	GOLDEN WHEEL	130.01.135	KH	
JL6105-0A	GOLDEN WHEEL	130.06.348	KP	--
JL6105-1A	GOLDEN WHEEL	130.06.106	KP	--
JL6105-2A	GOLDEN WHEEL	130.06.294	KP	--
JL6105-3A NBL	GOLDEN WHEEL	130.06.233	KP	NBL
JL6105-3A NO NBL	GOLDEN WHEEL	130.06.209	KP	--
JQ6100-0A	GOLDEN WHEEL	130.09.180	KH	
JS61003A	GOLDEN WHEEL	130.09.207	KH	
K-1830-HA7	FOMAX	130.05.428	KH	
K-1830-HAO	FOMAX	130.05.436	KH	
K-1830-HBO	FOMAX	130.09.006	KH	
K-1837-000	FOMAX	130.06.298	KP	NBL
K-1837-000 MF	FOMAX	130.06.125	KP	MF
KF220302	BARUDAN	130.10.039	KP	NBL
KF220302 NO NBL	BARUDAN	130.10.056	KP	--
KF220310	BARUDAN	130.01.357	KH	
KF220310 TS	BARUDAN	130.01.357TS	KH	
KF220440 NBL	BARUDAN	130.06.240	KP	NBL
KF220440 NO NBL	BARUDAN	130.06.348	KP	--
KF220710	BARUDAN	130.01.399	KH	
KF220710	BARUDAN	130.01.408	KH	
KF220710	BARUDAN	130.01.415	KH	
KF220710 DC20	BARUDAN	130.01.408DC20	KH	
KF220710 TS	BARUDAN	130.01.408TS	KH	
KF220780	BARUDAN	130.01.357TS	KH	
KF221000	BARUDAN	130.01.415	KH	

Original Number	Original Number of	CM CERLIANI Article Number	Line	NBL Type
KF221010 NBL	BARUDAN	130.06.240	KP	NBL
M1055B	TAJIMA	130.01.124	KH	
M1055E	TAJIMA	130.01.399	KH	
M1055ENWK	TAJIMA	130.01.399	KH	
M1055NWK	TAJIMA	130.01.399TS	KH	
M1055W	TAJIMA	130.01.399	KH	
M1055WT	TAJIMA	130.01.399	KH	
M1055WT(S)	TAJIMA	130.01.399TS	KH	
M1055WTS	TAJIMA	130.01.399	KH	
MA10A0120	MITSUBISHI	115.10.001	KH	
MA10A1120	MITSUBISHI	115.10.000	KH	
ME0503000 NBL	TAJIMA	130.06.240	KP	NBL
ME0503000 NO NBL	TAJIMA	130.06.348	KP	--
ME0505000000	TAJIMA	130.01.399	KH	
ME05050000TS	TAJIMA	130.01.399TS	KH	
ME0505000AMQ	TAJIMA	130.01.399	KH	
ME0505000AMQ TS	TAJIMA	130.01.399TS	KH	
ME0505010000	TAJIMA	130.01.399	KH	
ME0505010AMQ	TAJIMA	130.01.399	KH	
ME0505010AMQ	TAJIMA	130.01.408TS	KH	
ME05050112RY	TAJIMA	130.01.408	KH	
ME0505020AMQ	TAJIMA	130.01.408	KH	
ME0505020AMQ DC20	TAJIMA	130.01.408DC20	KH	
ME0505020AMQ TS	TAJIMA	130.01.408TS	KH	
ME05050212RY	TAJIMA	130.01.408	KH	
ME0505030000	TAJIMA	130.01.408	KH	
ME05050300TS	TAJIMA	130.01.408TS	KH	
ME0505E20AMQ	TAJIMA	130.01.415	KH	
ME0505E20AMQ TS	TAJIMA	130.01.415TS	KH	
ME20A0120	TAJIMA	130.09.207	KH	
MEC503000DBM	TAJIMA	130.10.039	KP	NBL
MEC503000DBM NO NBL	TAJIMA	130.10.056	KP	--
MEC505	TAJIMA	130.09.150	KH	
MEC5050000	TAJIMA	130.09.103	KH	
MEC5050000000	TAJIMA	130.09.150	KH	
MEC5050000TS	TAJIMA	130.09.103TS	KH	
MEC5050000TS	TAJIMA	130.09.150TS	KH	
MEC505000DBM	TAJIMA	130.09.150	KH	
MEC5050100	TAJIMA	130.09.150	KH	
MEC505010000	TAJIMA	130.09.150	KH	
MEC5050100TS	TAJIMA	130.09.150TS	KH	
MEC5050200RN	TAJIMA	130.09.150TS	KH	
MEC505TS	TAJIMA	130.09.150TS	KH	
MF00A0120	MITSUBISHI	130.05.473	KH	
MF01E0120	MITSUBISHI	130.05.376	KH	
MF01E0120 DC20	MITSUBISHI	130.05.376DC20	KH	
MF01E0120(SP)	MITSUBISHI	130.05.527	KH	
MF10E0125	MITSUBISHI	130.06.019	KP	--
MF10E0125 Magnet	MITSUBISHI	130.06.351	KP	Magnet
MF16A0120	MITSUBISHI	130.05.235	KH	
MF16A0120	MITSUBISHI	130.05.515	KH	NBL
MF16A0120 TS	MITSUBISHI	130.05.235TS	KH	
MF22B0120	MITSUBISHI	130.05.271	KH	
MF22B0120	MITSUBISHI	130.05.517	KH	
MF22B0120 TS	MITSUBISHI	130.05.517TS	KH	
MF25B0120	MITSUBISHI	130.09.006	KH	
MF25B0120	MITSUBISHI	130.09.210	KH	
MF25E0125	MITSUBISHI	130.10.000	KP	--
MF35A0120	MITSUBISHI	130.05.376	KH	
MF40A0120 DC20	MITSUBISHI	130.05.376DC20	KH	
MF40A0120 H style	MITSUBISHI	130.05.376	KH	
MF40A0120 K style	MITSUBISHI	130.05.424	KH	
MF40A0120 old	MITSUBISHI	130.05.430	KH	
MF40E0125	MITSUBISHI	130.06.298	KP	NBL
MF40E0125 MF	MITSUBISHI	130.06.125	KP	MF
MF40E0125 NO NBL	MITSUBISHI	130.06.019	KP	--
MF42A0120	MITSUBISHI	130.05.271	KH	
MF42B0120	MITSUBISHI	130.05.428	KH	
MF60A0120	MITSUBISHI	130.01.000	KH	
MF62B0120	MITSUBISHI	130.01.124	KH	



Original Number	Original Number of	CM CERLIANI Article Number	Line	NBL Type	Original Number	Original Number of	CM CERLIANI Article Number	Line	NBL Type
MF65B0120	MITSUBISHI	130.01.124	KH		R-190	MINERVA	130.11.170	KL	
MG44B0120	MITSUBISHI	130.09.207	KH		R235	GLOBAL	130.05.412	KH	
MG44E0125	MITSUBISHI	130.10.054	KP	NBL	R235 A	MINERVA	130.06.036	KP	--
MHK2	MEISTERGRAMM	130.09.150	KH		R290	GLOBAL	130.11.180	KL	
MN10A0120	MITSUBISHI	130.11.084	KL		S00688-901	BROTHER	130.09.500	KH	
MN12B0120	MITSUBISHI	130.15.016	KL		S00689-901	BROTHER	130.09.506	KH	
MN25A0120	MITSUBISHI	130.16.062	KH		S00690-301	BROTHER	130.10.510	KP	--
MN26A0125	MITSUBISHI	130.20.000	KP	--	S00690-301	BROTHER	X5.130.10.510	KP	--
MN26B0120	MITSUBISHI	130.19.010	KH		S00691-401	BROTHER	130.10.515	KP	--
MN27A0125	MITSUBISHI	130.17.000	KP	--	S00982-901	BROTHER	130.09.082	KH	
MN30A0120	MITSUBISHI	130.01.124	KH		S00982-901 SG	BROTHER	130.09.228	KH	
MN30A0120	MITSUBISHI	130.01.135	KH		S02603-001	BROTHER	130.05.414	KH	
MN50A0125	MITSUBISHI	130.17.015	KP	--	S02603-901	BROTHER	130.05.414	KH	
MN50E0120	MITSUBISHI	130.16.005	KH		S03245001	BROTHER	130.06.298	KP	NBL
MN50E0125	MITSUBISHI	130.17.015	KP	--	S06545-101	BROTHER	130.09.514	KH	
MN52A0125	MITSUBISHI	130.20.025	KP	--	S07425-111	BROTHER	130.11.216	KL	
MN52E0120 Reg.needle guard w/o Cap	MITSUBISHI	130.19.005R	KH		S07425-901	BROTHER	130.11.216	KL	
MN52E0120 w/o Cap	MITSUBISHI	130.19.005	KH		S07425-901 with special hard treatment	BROTHER	130.11.188	KL	
MN52E0120 w/o Cap	MITSUBISHI	130.19.030	KH		S07426-901	BROTHER	130.11.131	KL	
MN52E0125	MITSUBISHI	130.20.025	KP	--	S07427-901	BROTHER	130.11.219	KL	
MN57A0120 w/o Cap	MITSUBISHI	130.19.010	KH		S07427-901 With Special hard treatment	BROTHER	130.11.195	KL	
MN60A0125	MITSUBISHI	130.17.000	KP	--	S07428-901 w/o Cap w/o Sp.Treatment	BROTHER	130.16.055	KH	
MN60E0125	MITSUBISHI	130.17.000	KP	--	S07428-901 w/o Cap	BROTHER	130.16.054	KH	
MN62A0125	MITSUBISHI	130.20.015	KP	--	S07568-901 with special hard treatment	BROTHER	130.16.052	KH	
MN62E0120 w/o Cap	MITSUBISHI	130.19.030	KH		S07740-001	BROTHER	130.17.035	KP	--
MN74E0120	MITSUBISHI	130.15.030	KL		S07741-001	BROTHER	130.17.025	KP	--
MP00A0120	MITSUBISHI	130.15.024	KL		S07742-001	BROTHER	130.17.030	KP	--
MP02B0120	MITSUBISHI	130.15.024	KL		S09129-901	BROTHER	130.05.235	KH	
MP43A0120	MITSUBISHI	130.15.085	KL		S09263-901	BROTHER	130.15.128	KL	
MP43A0120 DC10 LAR	MITSUBISHI	130.15.085RDC10	KL		S09263-901 with special hard treatment	BROTHER	130.15.125	KL	
MP43A0120 DC10 Reg.needle guard	MITSUBISHI	130.15.085RDC10	KL		S09278-001	BROTHER	130.20.030	KP	--
MP43A0120 Reg.needle guard	MITSUBISHI	130.15.085R	KL		S09279-001	BROTHER	130.20.035	KP	--
MPZ01360	HAPPY	130.01.408	KH		S09280-001	BROTHER	130.20.040	KP	--
MS01A0120	MITSUBISHI	115.00.275	KH		S13612-901	BROTHER	130.16.061	KH	
MS01A1120	MITSUBISHI	115.00.276	KH		S13612-901 with special hard treatment	BROTHER	130.16.060	KH	
MS02E0125	MITSUBISHI	130.10.045	KP	NBL	S13613-901	BROTHER	130.16.053	KH	
MS02E0125 MF	MITSUBISHI	130.10.007	KP	MF	S13613-901 with special hard treatment	BROTHER	130.16.052	KH	
MS-119716A	MILLION SPECIAL	130.08.451	KK	--	S13614-901	BROTHER	130.16.056	KH	
MS17A0120	MITSUBISHI	115.10.001	KH		S13614-901	BROTHER	130.16.059	KH	
MS17A1120	MITSUBISHI	115.10.000	KH		S13615-901 w/o Cap	BROTHER	130.19.045	KH	
MT40A0125	MITSUBISHI	130.14.010	KP	--	S09278-001	BROTHER	130.19.045	KH	
MT50A0120	MITSUBISHI	130.12.146	KH		S13615-901 with special hard treatment	BROTHER	130.19.051	KH	
MT70A0120	MITSUBISHI	130.12.051	KH		S13616-901	BROTHER	130.19.045	KH	
MT70A0120 TTN	MITSUBISHI	130.12.051TTN	KH		S13616-901 w/o special hard treatment	BROTHER	130.19.050	KH	
MT70E0125 NBL	MITSUBISHI	130.14.021	KP	NBL	S13616-901 with special hard treatment	BROTHER	130.19.042	KH	
MT70E0125 NO NBL	MITSUBISHI	130.14.017	KP	--	S13616-901 with special hard treatment w/o Cap	BROTHER	130.19.051	KH	
MV01A0120	MITSUBISHI	130.11.155	KL		S09280-001	BROTHER	130.19.045	KH	
N2215244	IDEAL	130.05.343	KH		S13617-901 with special hard treatment	BROTHER	130.19.051	KH	
N2225284	IDEAL	130.06.159	KP	MF	S15661-101	BROTHER	115.10.011	KH	
N523404	IDEAL	130.06.108	KP	--	S15661-901	BROTHER	115.10.011	KH	
P413820	MEISTERGRAMM	130.09.150	KH		S15662-901	BROTHER	115.10.010	KH	
P413821	MEISTERGRAMM	130.09.150	KH		S15662-991	BROTHER	115.10.010	KH	
P413830	MEISTERGRAMM	130.10.039	KP	NBL	S15663-001	BROTHER	115.10.011	KH	
P810003	MEISTERGRAMM	130.01.399	KH		S15663-901	BROTHER	115.10.011	KH	
P810003TS	MEISTERGRAMM	130.01.399TS	KH		S15663-991	BROTHER	115.10.011	KH	
P975001X01	MITSUBISHI	130.01.124	KH		S18416-001	BROTHER	130.01.399	KH	
P975011	MITSUBISHI	130.01.000	KH		S21673-901	BROTHER	130.19.051	KH	
P975012X01	MITSUBISHI	130.01.000	KH		S21674-901	BROTHER	130.20.040	KP	--
P975014	MITSUBISHI	130.01.124	KH						
P975023X03	MITSUBISHI	130.05.430	KH						
P975027X01	MITSUBISHI	130.12.051	KH						
P975027X01 TTN	MITSUBISHI	130.12.051TTN	KH						
P975033X01	MITSUBISHI	130.09.210	KH						
P975041X01	MITSUBISHI	130.16.062	KH						
P976006X02	MITSUBISHI	130.06.019	KP	--					
P976006XD	MITSUBISHI	130.06.019	KP	--					
R190	GLOBAL	130.11.170	KL						



Original Number	Original Number of	CM CERLIANI Article Number	Line	NBL Type
S34847-901	BROTHER	130.12.051	KH	
S34847-901 TTN	BROTHER	130.12.051TTN	KH	
S35595-901	BROTHER	130.09.193	KH	
S35784-901	BROTHER	130.05.376	KH	
S35784-901 DC20	BROTHER	130.05.376DC20	KH	
S44833-001	BROTHER	130.09.511	KH	
S522 000235	MINERVA	130.05.412	KH	
S522 006036	MINERVA	130.06.036	KP	--
S59161-201	BROTHER	115.10.010	KH	
S59162-101	BROTHER	115.10.011	KH	
SA1391-002	BROTHER	130.05.414	KH	
SA1646-001	BROTHER	130.09.193	KH	
SA1668-011	BROTHER	130.11.188	KL	
SA1668-111	BROTHER	130.11.216	KL	
SA1669-011	BROTHER	130.11.122	KL	
SA1669-111	BROTHER	130.11.131	KL	
SA1670-011 w/o Cap	BROTHER	130.16.054	KH	
SA1670-111 w/o Cap	BROTHER	130.16.055	KH	
SA1677-011	BROTHER	130.11.195	KL	
SA1677-111	BROTHER	130.11.219	KL	
SA1678-011 w/o Cap	BROTHER	130.16.060	KH	
SA1678-111 w/o Cap	BROTHER	130.16.061	KH	
SA1681-011 w/o Cap	BROTHER	130.16.052	KH	
SA1681-111 w/o Cap	BROTHER	130.16.053	KH	
SA1683-011 w/o Cap	BROTHER	130.16.056	KH	
SA1683-111 w/o Cap	BROTHER	130.16.059	KH	
SA1685-002	BROTHER	130.15.125	KL	
SA1685-102	BROTHER	130.15.128	KL	

Original Number	Original Number of	CM CERLIANI Article Number	Line	NBL Type
SA1689-002 w/o Cap	BROTHER	130.19.051	KH	
SA1689-102 w/o Cap	BROTHER	130.19.045	KH	
SA1692-002 w/o Cap	BROTHER	130.19.042	KH	
SA1692-102 w/o Cap	BROTHER	130.19.050	KH	
SA1694-002 w/o Cap	BROTHER	130.19.051	KH	
SA1694-102 w/o Cap	BROTHER	130.19.045	KH	
SA1698-001	BROTHER	130.05.271	KH	
SA1698-001 open type	BROTHER	130.05.517	KH	
SA1720-001	BROTHER	130.09.176	KH	
SA1852-001	BROTHER	130.01.147	KH	
SA1881-001	BROTHER	115.00.275	KH	
SA1882-001	BROTHER	115.00.276	KH	
SA1890-101	BROTHER	115.10.011	KH	
SA1890-201	BROTHER	115.10.011	KH	
SA1892-001	BROTHER	115.10.010	KH	
SA1894-001	BROTHER	115.10.011	KH	
SA1931-001	BROTHER	130.05.414	KH	
SA2036-101	BROTHER	130.09.514	KH	
SA2173-001	BROTHER	115.10.010	KH	
SA2173-101	BROTHER	115.10.010	KH	
SA2173-201	BROTHER	115.10.010	KH	
SA2173-301	BROTHER	115.10.010	KH	
SA8197-101	BROTHER	115.10.011	KH	
TME-5005	TAJIMA	130.01.399	KH	
TME-5005T	TAJIMA	130.01.399	KH	
TMP030500000	TAJIMA	130.16.062	KH	
Z820220 SET	BARATTO	130.30.100	KK	--
Z820260 SET	BARATTO	130.30.120	KP	--

We are honored that you chose



We look forward to serving you again in the future

Vi ringraziamo per aver scelto



Speriamo di potervi servire ancora in futuro

Printed in January 2010

FINE ADJUSTMENT SYSTEM OF THE NEEDLE GUARD ON VERTICAL ROTARY HOOKS

It is well known that lock stitching is created when the hook point grazes the needle, and catches the loop formed by the needle thread.

The innovative idea of the **CM Cerliani** patent produces a fine adjustment of the peripheral needle guard fastened with only two screws to the hook, without the necessity of the third screw for the mere adjustment function and thus applicable on all existing vertical hooks. Furthermore, the patented method turns out to be simpler and more economic, needing one less screw than the known system and allowing the adjustment of the needle guard directly on the sewing machine.

The needle guard, bent naturally inwards, is forced outwards by unscrewing the adjusting screw placed between the fastening screw and the point of the needle guard in correspondence with the hook point, thus obtaining the necessary adjustment without need to take off the hook.

The innovation produced by this patent allows the fitters and technical assemblers to adjust with precision the needle guard through a simple cheap and reliable operation.

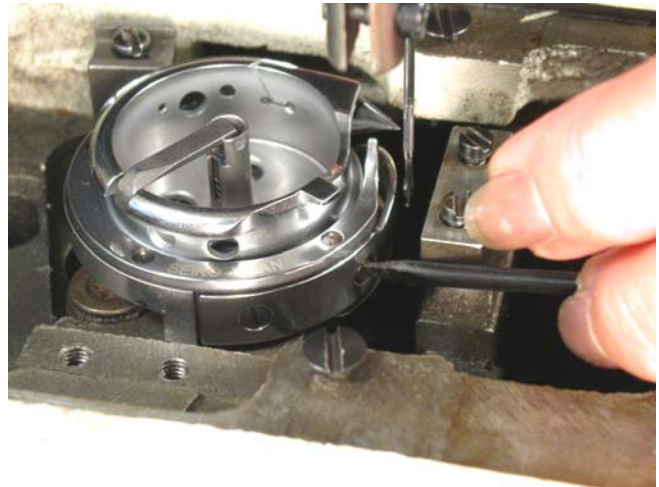
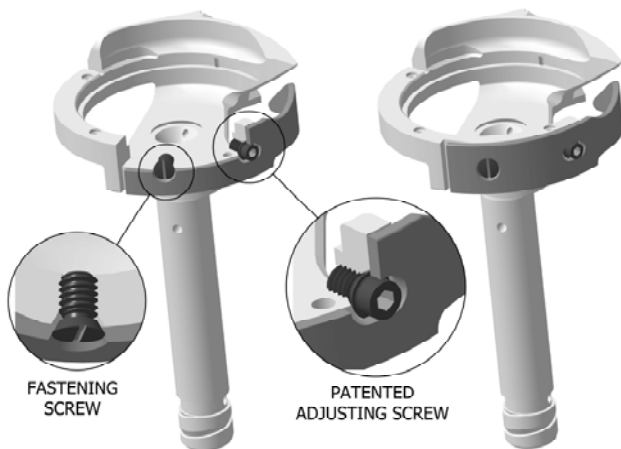

CM Cerliani: we invent.... the others try to follow us!

Ask for this feature as "R" version hook



CM Cerliani S.r.l.

Società a socio unico

Via Mascherpa, 61

I-27100 Pavia-(ITALY)

Tel. : +39/0382/423413

Fax : +39/0382/423319

E-Mail: info@cerliani.it

URL: <http://www.cerliani.it>

C.F. e P.IVA (VAT Nr.) 02175920186

Company subjected to management and coordination by the controlling company CERLIANI S.p.A.
(ex Art.2497-bis C.C.)

From the library of: Superior Sewing Machine & Supply LLC